

SEZIONE A-A

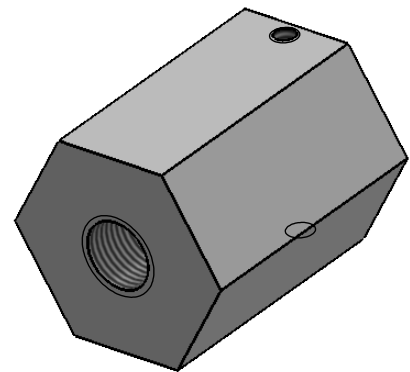

Material: 4140 carbon steel

Measures: mm

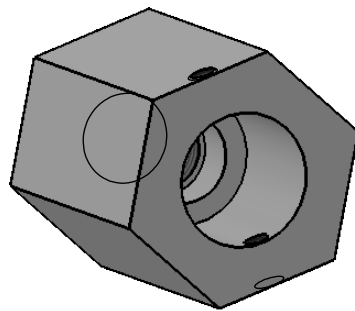

Rev.	Mod.	Dt. Mod.	Ver.	Dt. Ver.	Appr.	Dt. Appr.
Descr. Mod.						
Esagono			Scala 1:1	Smussi non quotati: Sm. 0.5x45°	Quote senza indicazioni di tolleranza. Grado di precisione FINE secondo UNI EN 22768/1	
				Raggi non quotati: R 0.4		
Tratt. termic.: Tratt. superf.:				Stato:	Massa: 0.19	
				Disegnatore:	Data:	
Descrizione:				Codice:	Indice	
Descrizione agg.:				Formato A4		Foglio 1/1