

Milled recess for half blade thickness.  
View from Bottom.

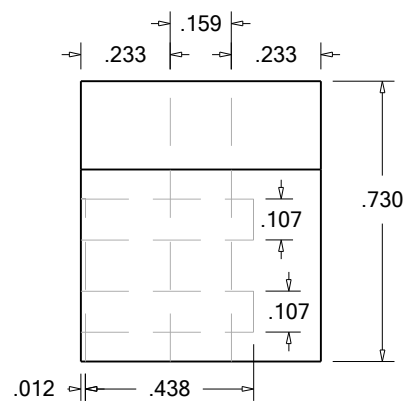
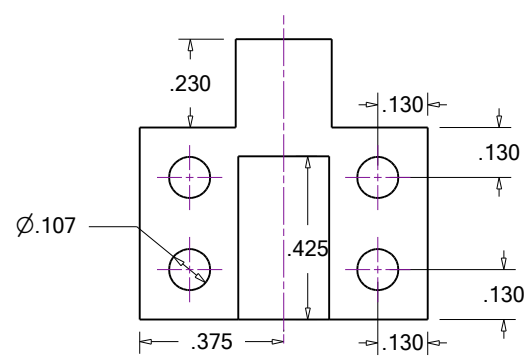

.107 holes tapped 6-32 4 places.  
.159 hole tapped 10-32 one place.  
Aluminum or 3D printed with solid infill.  
All holes tapped manually even if 3D printed.

Blade holder is fastened to the slotted bar  
with a 10-32 allen cap screw. (not shown)  
A knurled thumb screw could be used in place  
of the allen cap screw.

GasketCutter	
BladeHolder	
03/06/2025	JR