

SEZIONE A-A

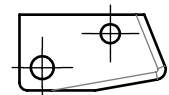
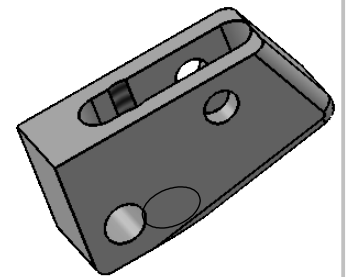
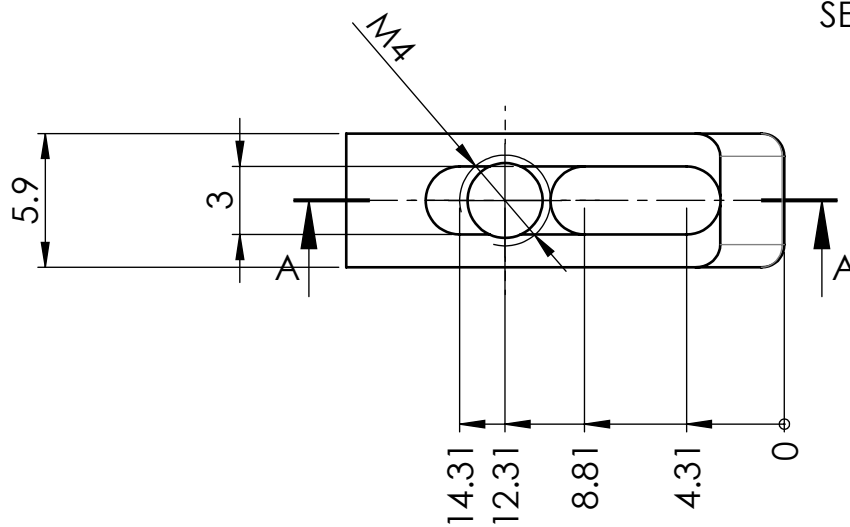
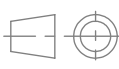

MATERIAL: CARBON STEEL

SCALE 1:1

Rev.	Mod.	Dt. Mod.	Ver.	Dt. Ver.	Appr.	Dt. Appr.
Descr. Mod.						
CUTTER_4			Scala 3:1	Smussi non quotati: Sm. 0.5x45°	Quote senza indicazioni di tolleranza. Grado di precisione FINE secondo UNI EN 22768/1	
				Raggi non quotati: R 0.4		
Tratt. termic.:			Stato:			Massa: 0.01
Tratt. superf.:			Disegnatore:			Data:
Descrizione:			Codice:			Indice
Descrizione agg.:						Formato A4
						Foglio 1/1