

Ø 8 (PITCH: 1 TURN IN 250 (mm))

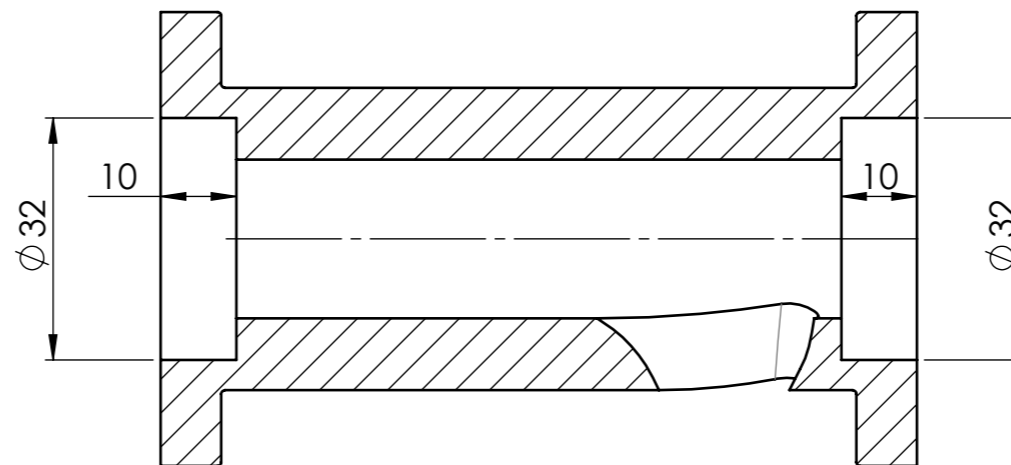

SEZIONE A-A

MATERIAL : CARBON STEEL OR PLA

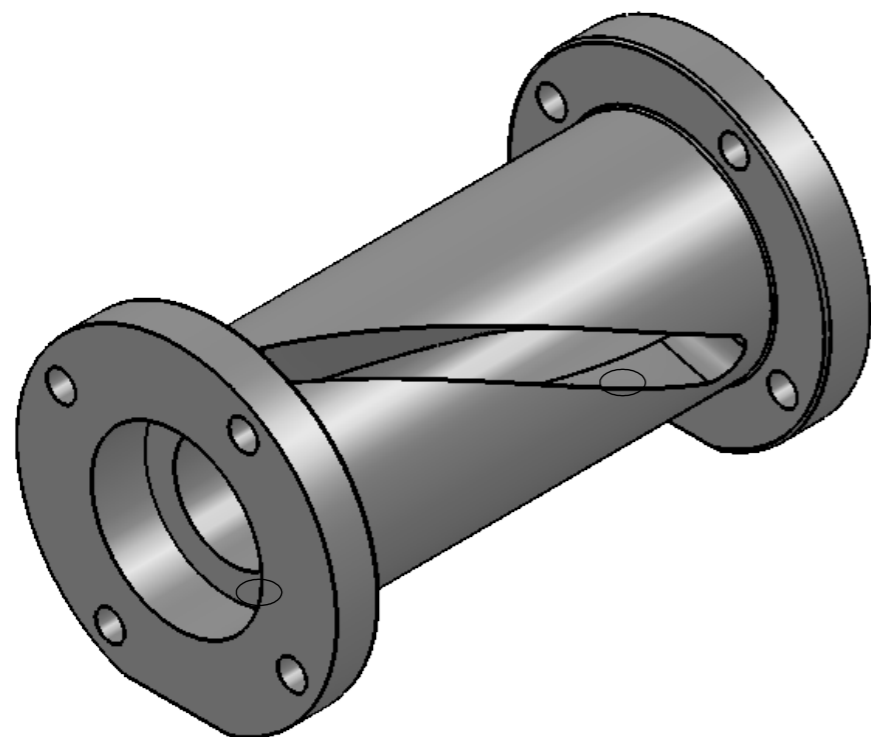

Rev. 0	Mod.	Dt. Mod.	Ver.	Dt. Ver.	Appr.	Dt. Appr.
Descr. Mod.						
GUDIA_CURVA		Scala	Smussi non quotati: Sm. 0.5x45°	Quote senza indicazioni di tolleranza. Grado di precisione FINE secondo UNI EN 22768/1		
		1:1	Raggi non quotati: R 0.4			
Tratt. termic.:			Stato: RILASCIATO	Massa: 0.77		
Tratt. superf.:			Disegnatore:	Data:		
Descrizione:		GUIDA CURVA L=250				Indice 0
Descrizione agg.:						Formato A3
						Foglio 1/1