

SEZIONE B-B

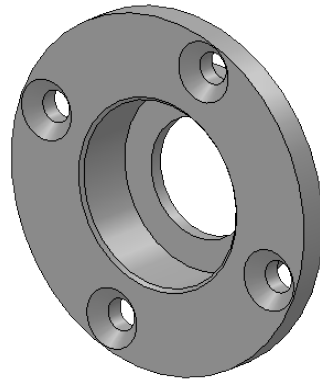

**MATERIAL: STEEL 1.050 (C45)**

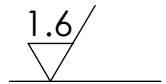
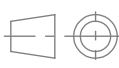

Rev.	Mod.	Dt. Mod.	Ver.	Dt. Ver.	Appr.	Dt. Appr.
Descr. Mod.						
Coperchio_frontale			Scala <b>1:1</b>	Smussi non quotati: Sm. 0.5x45°	Quote senza indicazioni di tolleranza. Grado di precisione FINE secondo UNI EN 22768/1	
				Raggi non quotati: R 0.4		
Tratt. termic.:				Stato:	Massa: 0.07	
				Disegnatore:	Data:	
Tratt. superf.:			Codice:			Indice
Descrizione:						Formato <b>A4</b>
Descrizione agg.:						Foglio <b>1/1</b>