

### SECTION ON A - A

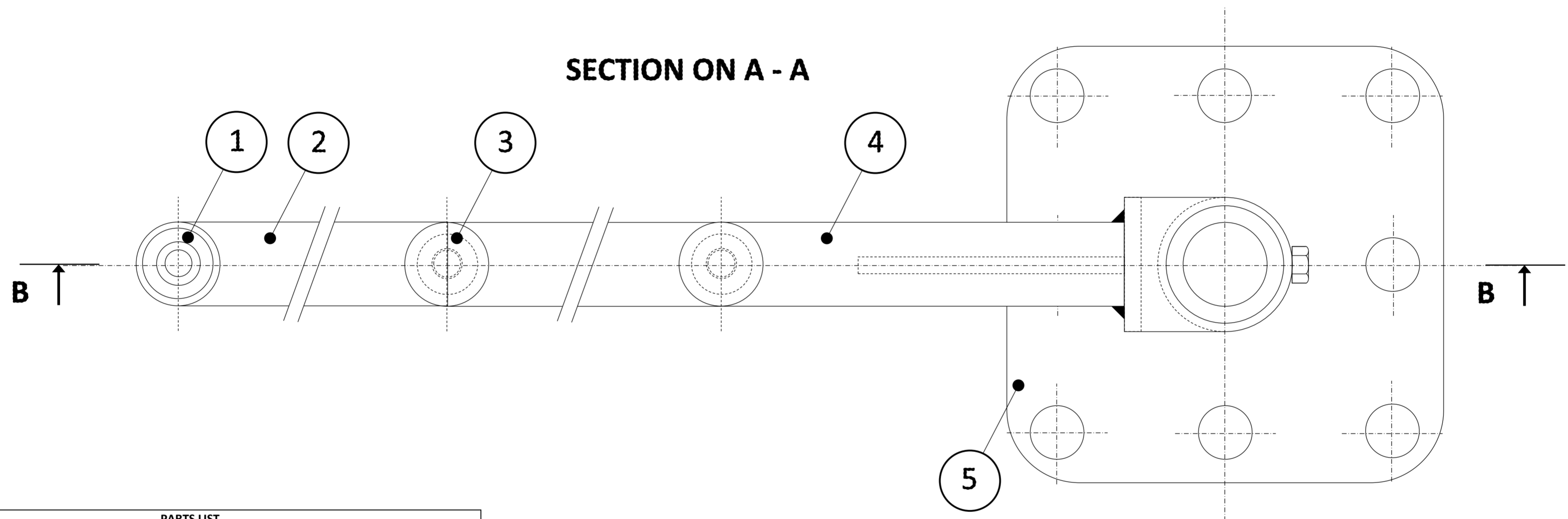

#### PARTS LIST

PART No	NAME	No OFF	MATERIAL
1	GIMBLE CUP	1	MILD STEEL
2	DOUBLE HINGED ARM (25 x 25 mm SQUARE)	2	MILD STEEL
3	ARM SPIGOT	2	MILD STEEL
4	SINGLE HINGED ARM	1	MILD STEEL
5	VERTICAL SUPPORT BASE PLATE	1	MILD STEEL
6	VERTICAL SUPPORT TUBE	1	MILD STEEL
7	ADJUSTABLE VERTICAL AXIS SUPPORT END PLATE	2	MILD STEEL
8	ADJUSTABLE VERTICAL AXIS SUPPORT SLEEVE	1	MILD STEEL
9	LOCK SCREW BOSS	2	MILD STEEL
10	LOCK SCREW HANDLE	2	MILD STEEL
11	M8 LOCK SCREW KNOB	2	PLASTIC
12	M8 WELD NUT	1	MILD STEEL
13	BASE PLATE VERTICAL SUPPORT SLEEVE	1	MILD STEEL
14	ADJUSTABLE VERTICAL AXIS SUPPORT FRONT PLATE	1	MILD STEEL
15	SINGLE HINGED ARM SUPPORT WEB	1	MILD STEEL
16	CUSTOM M8 WASHER	4	BRASS
17	M8 HALF NUT	2	BZP/STAINLESS STEEL
18	ARM HINGE BEARING CARRIER	2	MILD STEEL
19	F6882RS SEALED FLANGED DEEP GROOVE BEARING	4	—
20	ARM SPIGOT BEARING PLATE	2	BRASS
21	M8 LINEAR BALL JOINT	1	BZP/STAINLESS STEEL
22	ARM SUPPORT CUP	1	ALUMINIUM
23	M8 MACHINE SCREW	1	BZP/STAINLESS STEEL

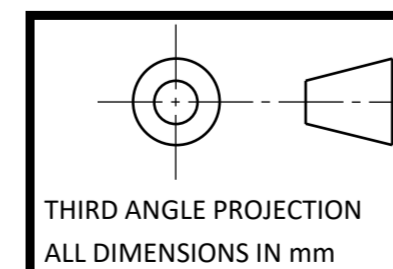

<b>DRAWN</b>	Poppa Bird
<b>Drq No</b>	N/A
<b>MATERIAL</b>	See parts list
<b>SCALE</b>	1:1

<b>TITLE: Welding Arm Support</b>	
SHEET 1 of 4	
PAPER SIZE A3	

1	21/01/26
A	08/12/26
<b>ISSUE</b>	<b>DATE</b>

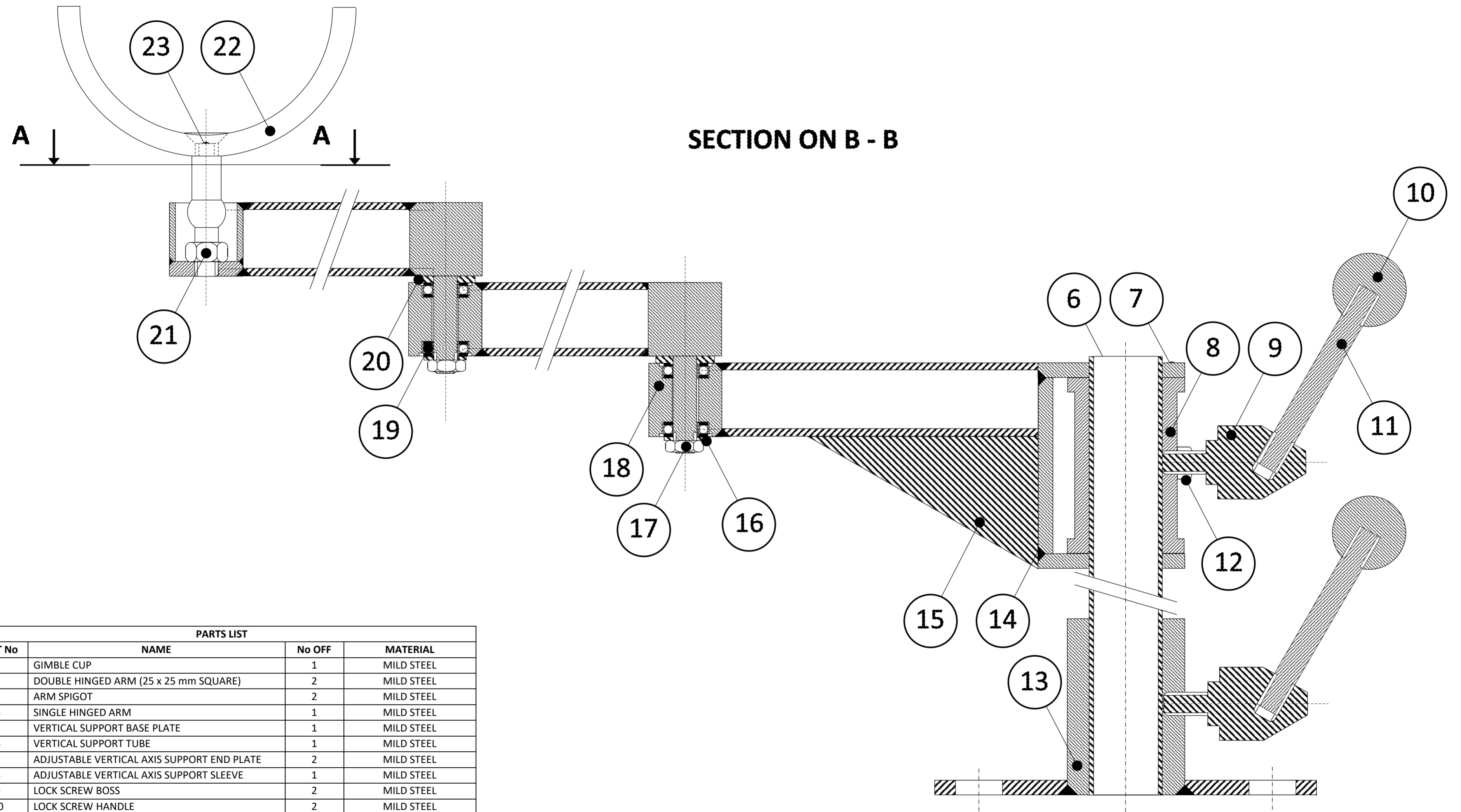

**PARTS LIST**

PART No	NAME	No OFF	MATERIAL
1	GIMBLE CUP	1	MILD STEEL
2	DOUBLE HINGED ARM (25 x 25 mm SQUARE)	2	MILD STEEL
3	ARM SPIGOT	2	MILD STEEL
4	SINGLE HINGED ARM	1	MILD STEEL
5	VERTICAL SUPPORT BASE PLATE	1	MILD STEEL
6	VERTICAL SUPPORT TUBE	1	MILD STEEL
7	ADJUSTABLE VERTICAL AXIS SUPPORT END PLATE	2	MILD STEEL
8	ADJUSTABLE VERTICAL AXIS SUPPORT SLEEVE	1	MILD STEEL
9	LOCK SCREW BOSS	2	MILD STEEL
10	LOCK SCREW HANDLE	2	MILD STEEL
11	M8 LOCK SCREW KNOB	2	PLASTIC
12	M8 WELD NUT	1	MILD STEEL
13	BASE PLATE VERTICAL SUPPORT SLEEVE	1	MILD STEEL
14	ADJUSTABLE VERTICAL AXIS SUPPORT FRONT PLATE	1	MILD STEEL
15	SINGLE HINGED ARM SUPPORT WEB	1	MILD STEEL
16	CUSTOM M8 WASHER	4	BRASS
17	M8 HALF NUT	2	BZP/STAINLESS STEEL
18	ARM HINGE BEARING CARRIER	2	MILD STEEL
19	F6882RS SEALED FLANGED DEEP GROOVE BEARING	4	—
20	ARM SPIGOT BEARING PLATE	2	BRASS
21	M8 LINEAR BALL JOINT	1	BZP/STAINLESS STEEL
22	ARM SUPPORT CUP	1	ALUMINIUM
23	M8 MACHINE SCREW	1	BZP/STAINLESS STEEL

<p>THIRD ANGLE PROJECTION ALL DIMENSIONS IN mm</p>	<b>DRAWN</b> Poppa Bird <b>Drq No</b> N/A <b>MATERIAL</b> See parts list	<b>TITLE: Welding Arm Support</b>	1	21/01/26
	<b>SCALE</b> 1:1		<b>SHEET 2 of 4</b>	<b>PAPER SIZE A3</b>

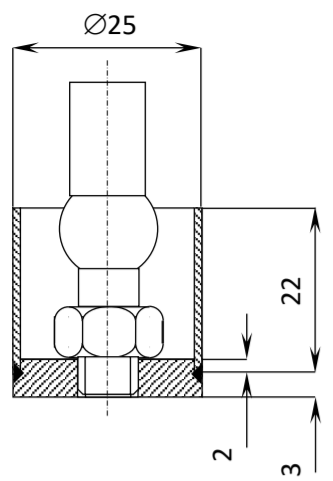

**#1 GIMBLE CUP**

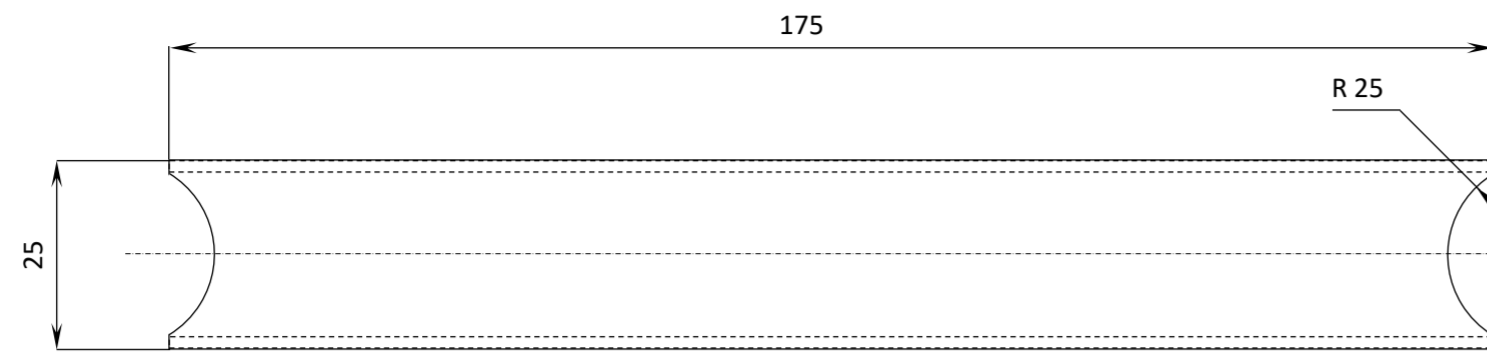

**#2 DOUBLE HINGED ARM**

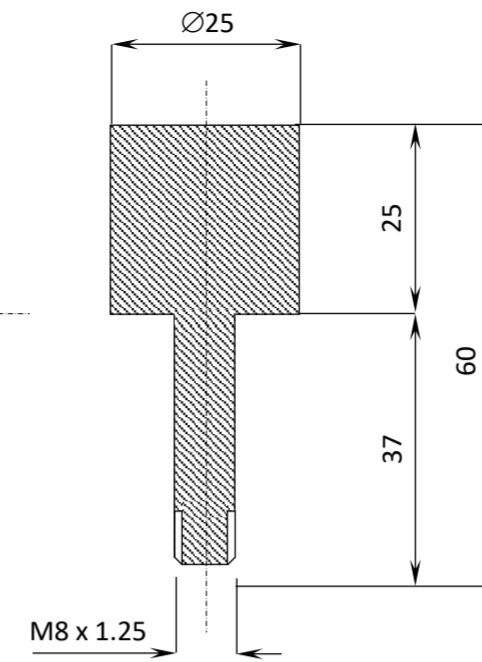

**#3 ARM SPIGOT**

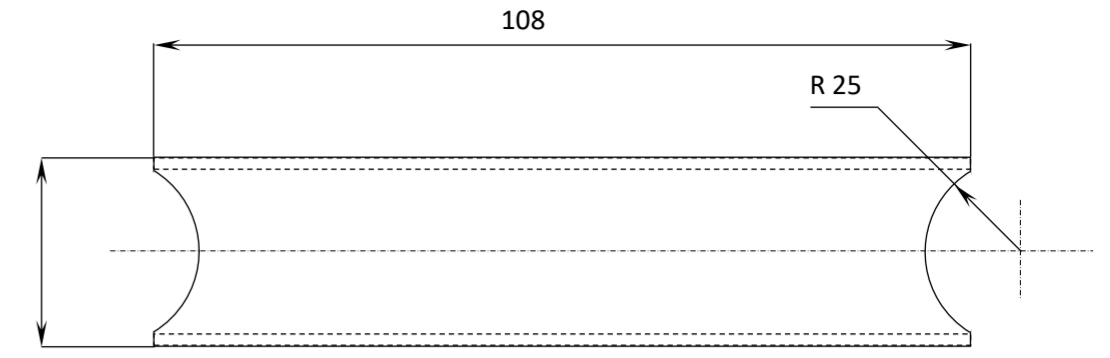

**#4 SINGLE HINGED ARM**

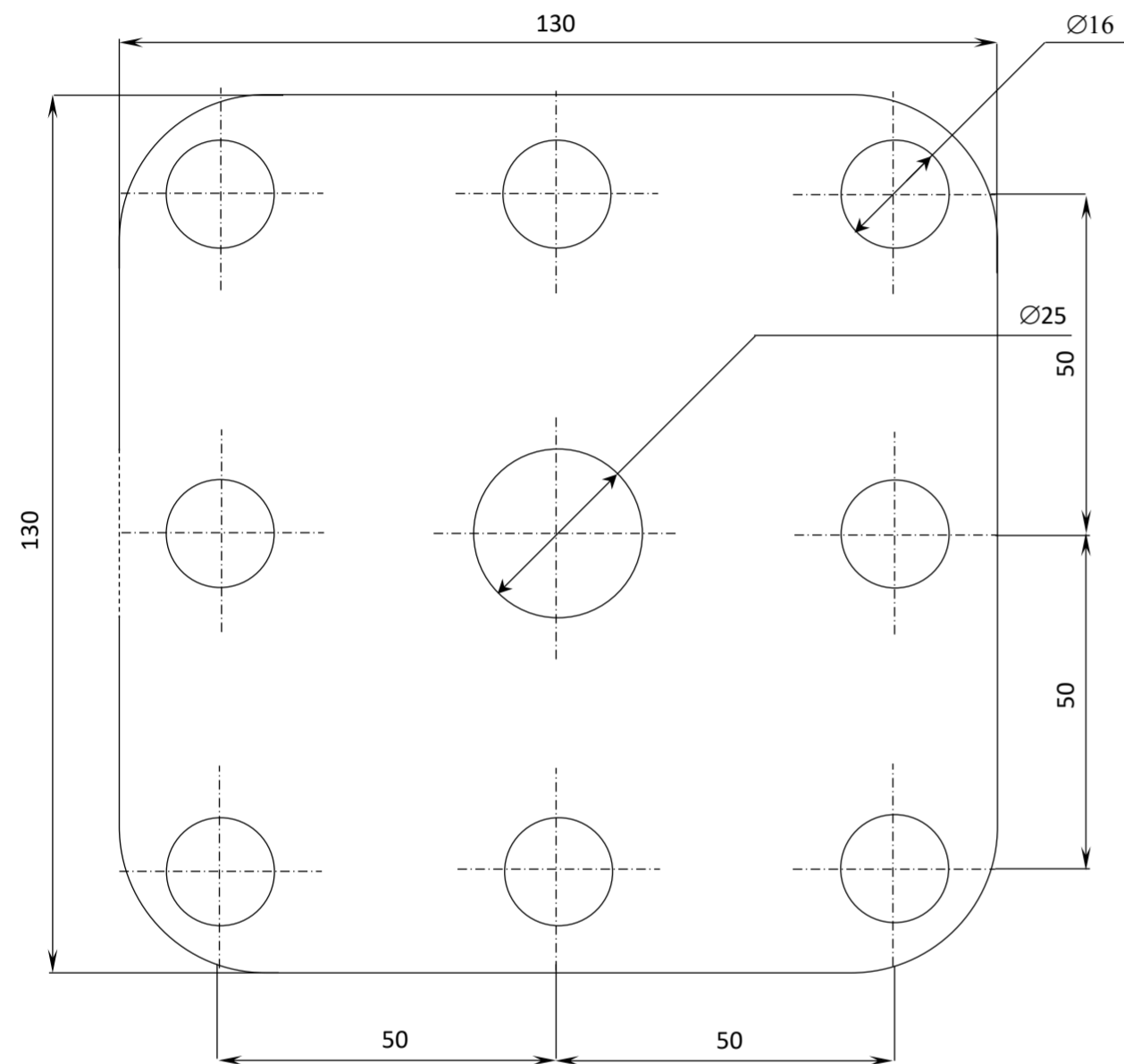

**#5 VERTICAL SUPPORT BASE PLATE**

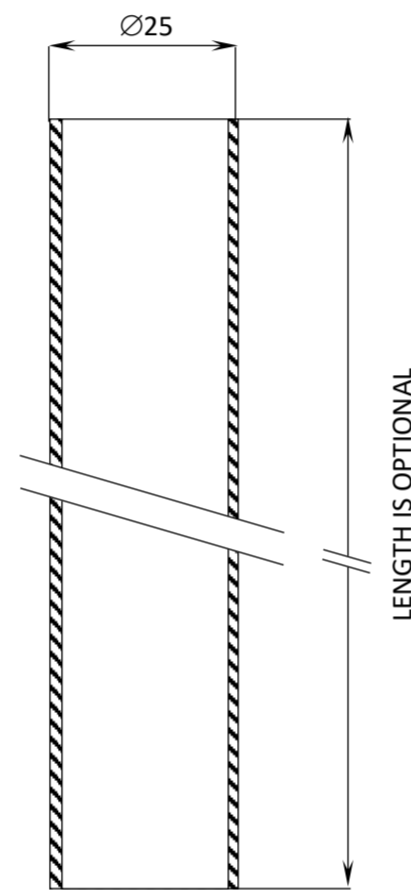

**#6 VERTICAL SUPPORT TUBE**

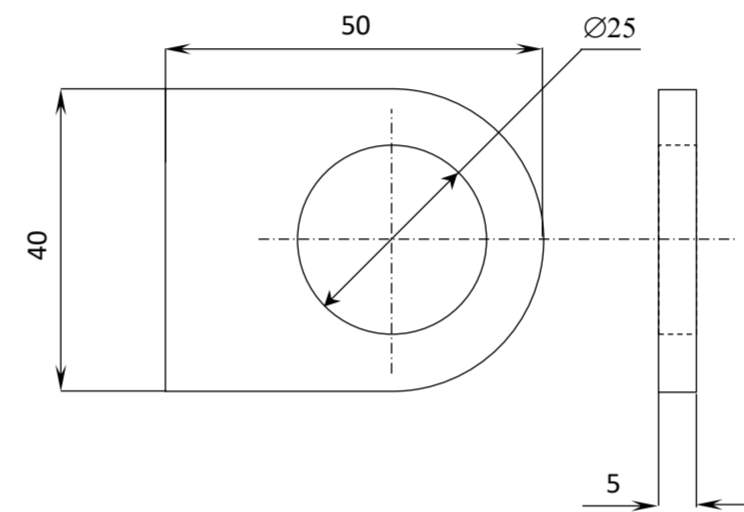

**#7 ADJUSTABLE VERTICAL AXIS SUPPORT END PLATE**

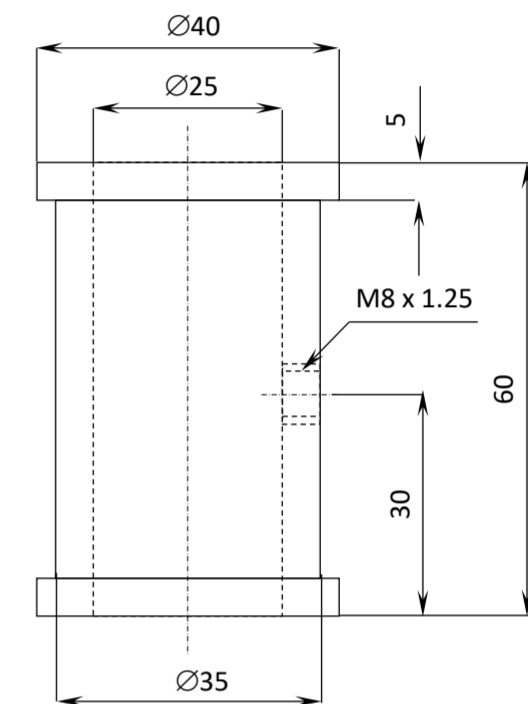

**#8 ADJUSTABLE VERTICAL AXIS SUPPORT SLEEVE**

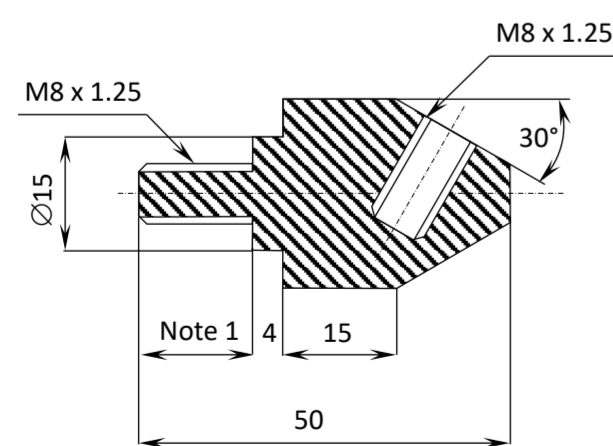

**#9 LOCK SCREW BOSS**

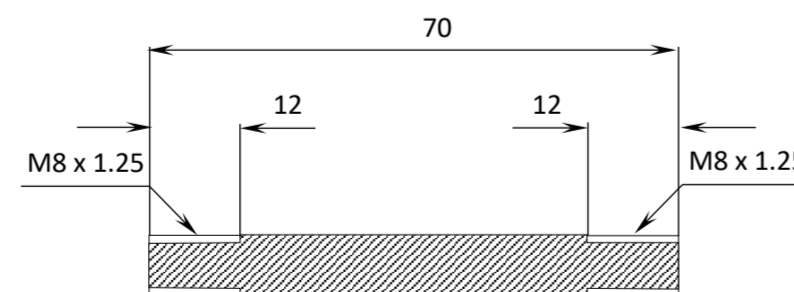

**#10 LOCK SCREW HANDLE**

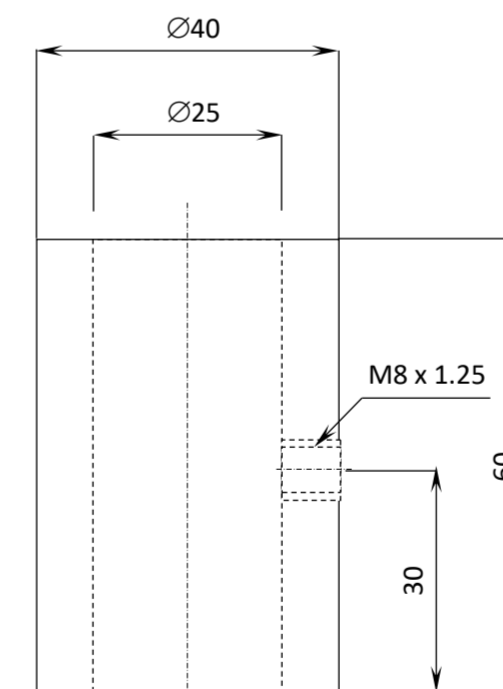

**#13 BASE PLATE VERTICAL SUPPORT**

**NOTES**  
 1. The length of the thread is determined by screwing the boss into the relevant hole and adjusting the length of the thread on a lathe to position the handle in your preferred position.

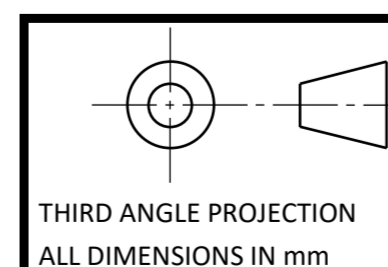

<b>DRAWN</b>	Poppa Bird
<b>Drq No</b>	N/A
<b>MATERIAL</b>	See parts list
<b>SCALE</b>	1:1

**TITLE: Welding Arm Support**

SHEET 3 of 4

PAPER SIZE A3

1	21/01/26
A	08/12/26
<b>ISSUE</b>	<b>DATE</b>

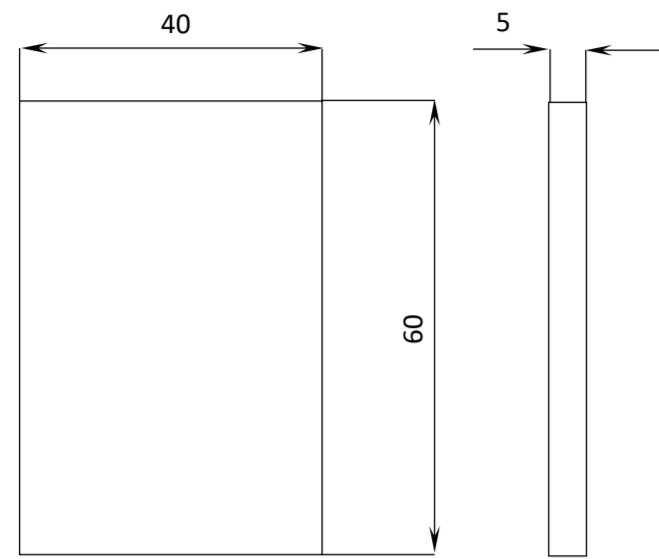

**#14 ADJUSTABLE  
VERTICAL AXIS SUPPORT**

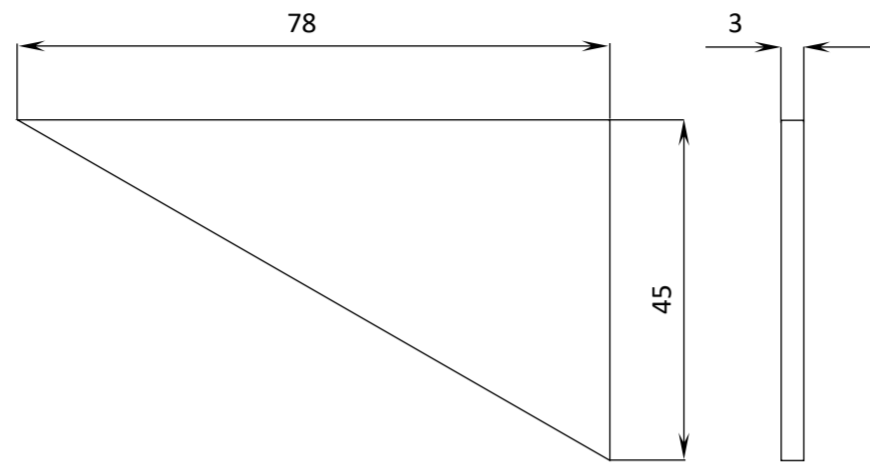

**#15 SINGLE HINGED  
ARM SUPPORT WEB**

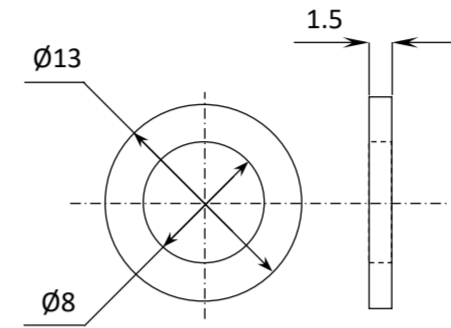

**#16 CUSTOM M8  
WASHER**

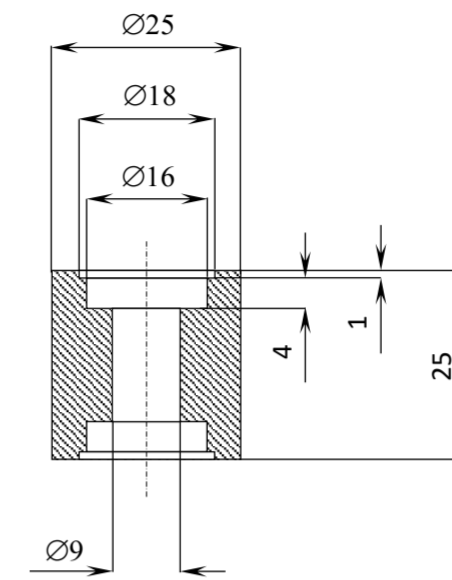

**#18 ARM HINGE  
BEARING CARRIER**

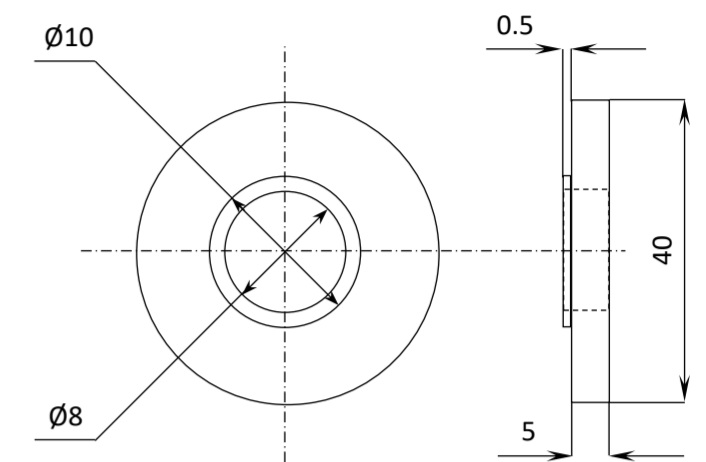

**#20 ARM SPIGOT  
BEARING PLATE**

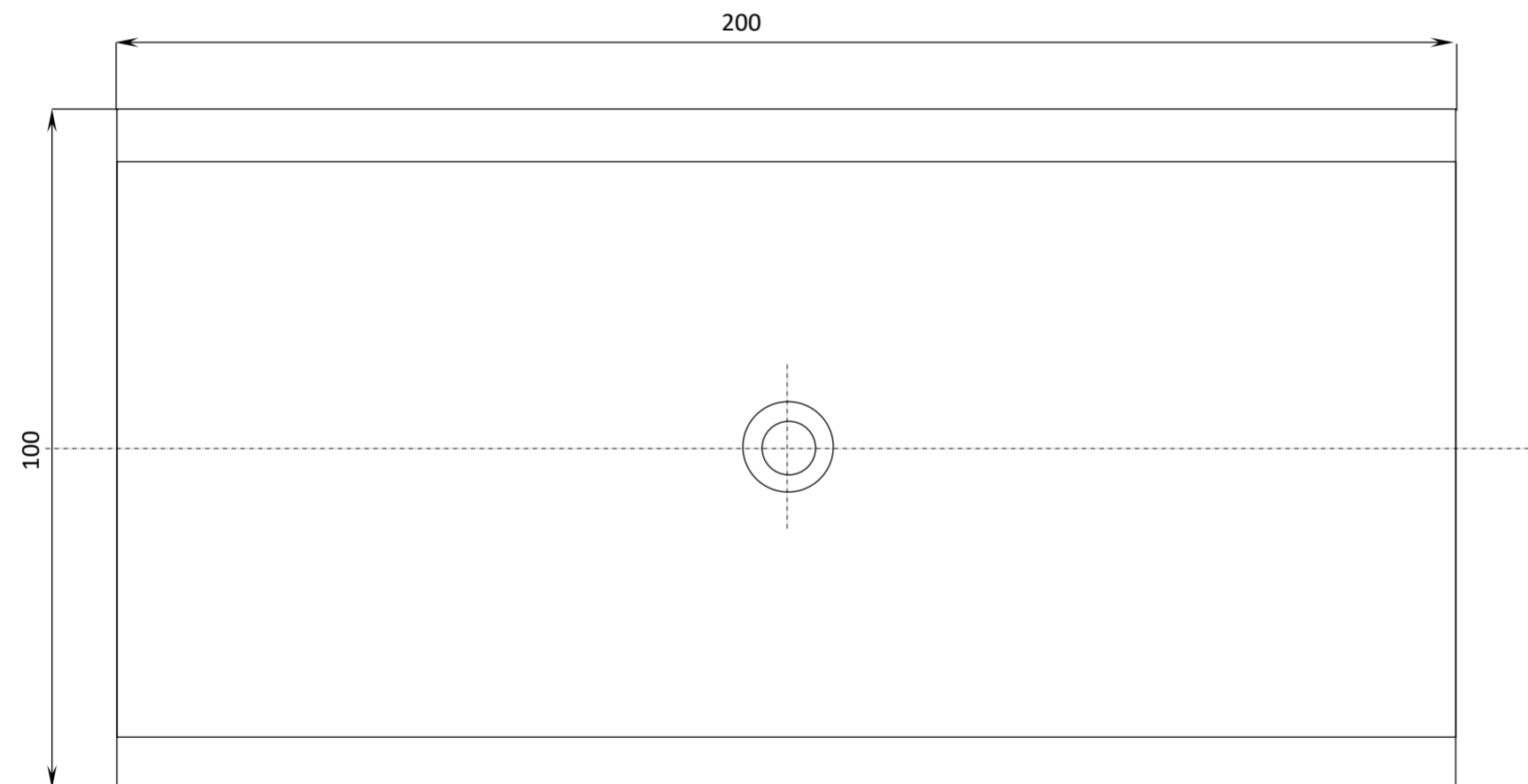

**#22 ARM SUPPORT CUP**

**NOTES**

- The length of the thread is determined by screwing the boss into the relevant hole and adjusting the length of the thread on a lathe to position the handle in your preferred position.

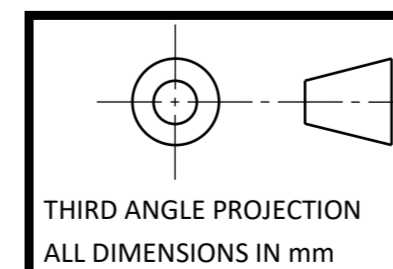

<b>DRAWN</b>	Poppa Bird
<b>Drng No</b>	N/A
<b>MATERIAL</b>	See parts list
<b>SCALE</b>	1:1

**TITLE: Welding Arm Support**

<b>SHEET 4 of 4</b>	<b>PAPER SIZE A3</b>	<b>ISSUE</b>	<b>DATE</b>
		1	21/01/26
		A	08/12/26