

TouchDRO APP USER MANUAL

Application Version 2.5.10 Build 2016-08-12
TouchDRO firmware versions 1.33 & 2.0

Many thanks to Yuriy for his contributions to this manual!

<https://www.yuriystoys.com/> for the TouchDRO board only

blu-dro.com for the TouchDRO board & Enclosure

INDEX

Installing the TouchDRO Application	3
Installing and Connecting the Touch-DRO	4
Pairing the blu-DRO	4
The Main Display	5
Axis Detail Menu	6 - 8
Settings Menu	9- 13
X, Y and Z Axis Calibration	14
Default Workspace	15
Setting An Absolute Dimension	15
Finding Work Center	16
Hole Circle Function	16
The Tool Library	17
Setting a Tool Offset	17
Adding a Point	17
Arbitrary Hole Circle Function	17
Step and Repeat Function	18
Adding A Tachometer	18
Presetting A Dimension	18
Appendix	19
Trouble Shooting Guide	25

blu-dro.com for the blu-DRO unit
yuriystoys.com for the TouchDRO PCB only
Google Play Store for the TouchDRO App
Taytools.com for iGage DRO's
[Dave M YouTube Channel](#)

Installing The TouchDRO Application

The TouchDRO application must be installed in a smart phone or table which uses an Android operating system of at least 4.0, has Bluetooth capability and a 7" screen with 800 x 480 or better resolution is recommended. The application can be downloaded from the Google Play Store and the icon for the application is shown below. Search for 'touchdro'.



1. Yuriy's Toys
TouchDRO
Yuriy's Toys
★★★★★ FREE

Once it has been downloaded and installed then run the application. When first run a popup will ask for access to the Bluetooth connections on your tablet or phone. Click allow so the application can access your Bluetooth connections in order to connect with the TouchDRO's Bluetooth interface. You will be pairing with it later. Also note a popup will appear indicating axis calibration is necessary. You can elect to check the 'do not show again' box and then click the 'got it' button. Make sure the application is not running before proceeding to connect and install the TouchDRO in the next section.

Installing And Connecting the TouchDRO

Mount the TouchDRO where stray magnetic fields are less likely to affect its operation. This should be away from motor controllers and any AC wiring. Connect each axis to the appropriate outlet BEFORE applying power. Connections are shown below. Note the blu-DRO uses micro-b USB connectors for scale connections. Some scales use older Mini-B connectors and may not be compatible or require an adapter.



Next connect the supplied power adapter and insert it into a wall outlet. The TouchDRO PCB is now up and running. NOTE: The supplied power adapter is a switching type supply which may result in unstable or constantly changing of 1/10 digits. In this case use a transformer type power adapter between 7VDC and 15VDC at 200ma as described in the appendix.

Pairing The TouchDRO

Go to the settings section of your device running the TouchDRO app to begin scanning for Bluetooth devices to connect with. After the scan is complete you will see a device that should be labeled HC-05. This is the TouchDRO interface. I have seen them labeled differently however. Select it for pairing and enter 1234 for the pin when asked. Once the device is connected open the TouchDRO application and select Connect located in the top right of the screen. Then highlight the HC-05 device. The application is now connected and moving any axis will be registered in the main display. Confirm that all connected axes are functioning.

The Main Display

The main TouchDRO display is shown below. The actual layout may vary depending on your device, Android version, and screen resolution.

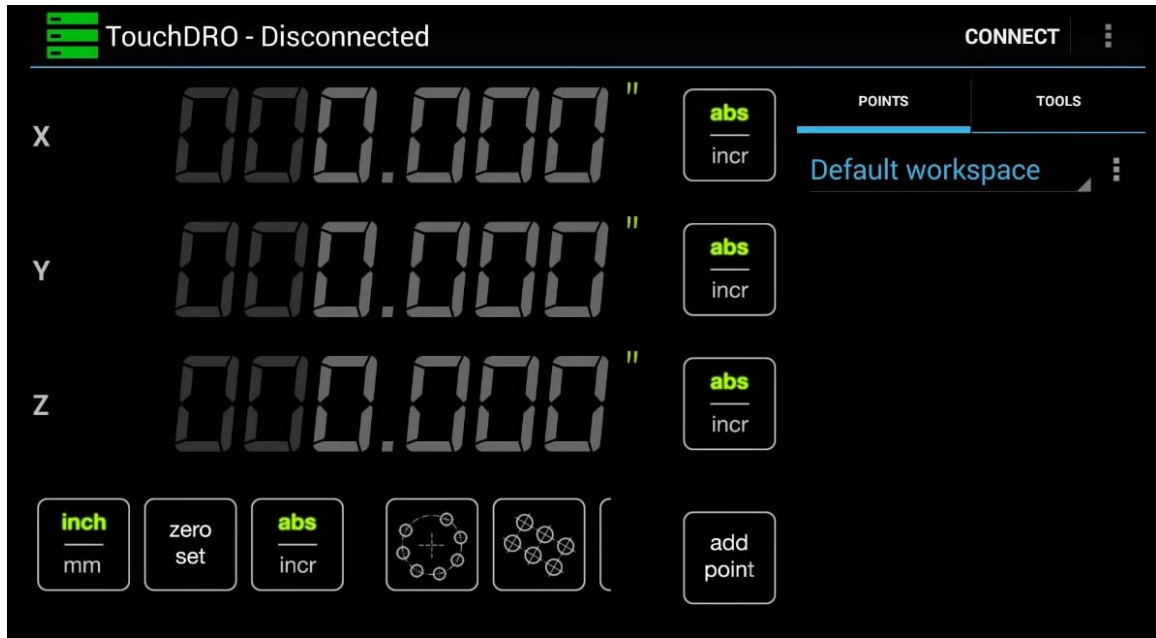

The top of the screen shows disconnected. Select CONNECT at the right and then select the TouchDRO (HC-05) to connect the application to the blu-DRO unit using a Bluetooth connection. The position digits will then light up green once connected.

The vertical buttons next to axis position digits allow the selection of either an incremental readout or absolute position readout. With incremental coordinates, the last point traveled and set to zero becomes the new reference point on which the operator bases his next move. Absolute coordinates are defined as each position on the work piece is unique.

The bottom row of buttons can be scrolled left or right to see all of the functions available. The first button selects the readout units to either metric or imperial.

Button selections from left to right are:

Set units to inch or millimeter

Set all axes to zero. Selecting an axis digits allows setting that axis to zero alone.

Set all to absolute or incremental positioning

Set up a hole circle pattern function

Set up a hole pattern function

Axis Details Menu

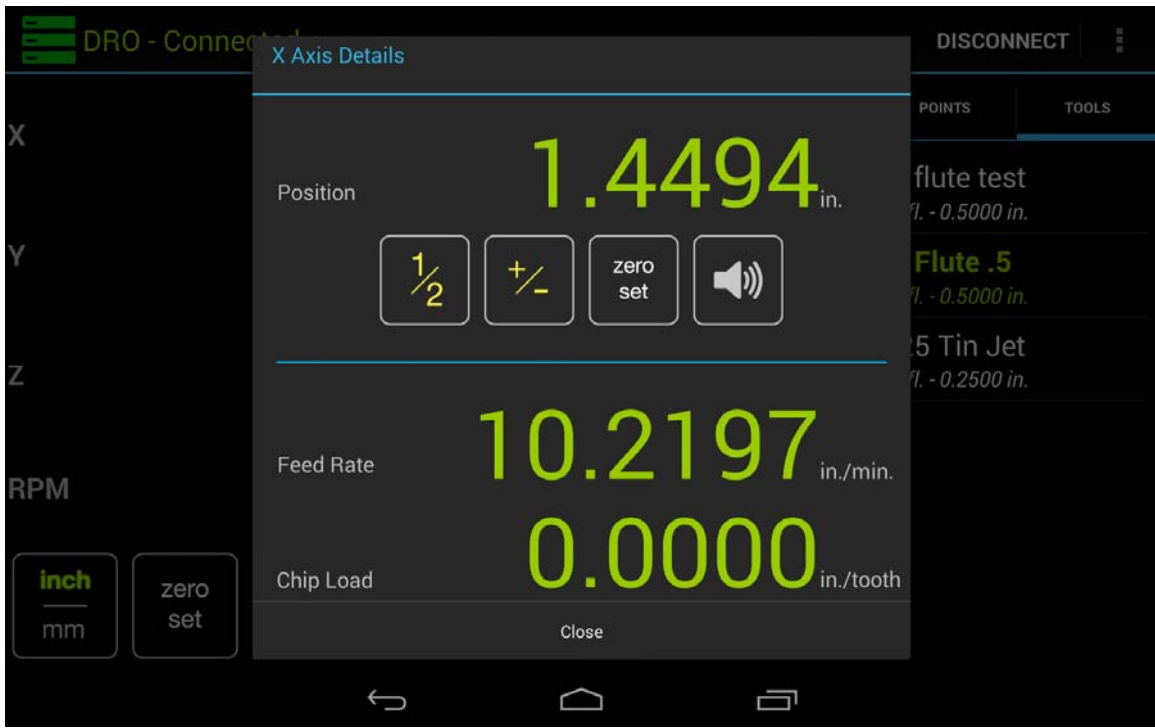

Axis details view is accessed by briefly selecting the axis readout digits while the DRO is in the "Connected" state (readout text appears green). The view is intended to provide access to several axis-specific functions, as well as real-time feed rate and chip load displays.

Position Display



The position digits represent the current axis position. Note it takes into accounts the selected units and coordinate system (absolute or incremental). A quick select of the digits will bring up the Axis Details menu and a long touch brings up the Set Dimensions menu.

Feed Rate



This displays the current feed rate when the axis is in motion. The value can be either positive or negative, depending on the direction of travel. The value is refreshed at a 2Hz frequency (two times per second) regardless of the velocity.

Chip Load



Displays the chip load when the axis is in motion and a tool has been selected. The value is calculated by dividing the feed rate by the product of RPM* and tooth count. When no tool is selected and/or the tachometer is disabled, the display will be disabled and a toast will briefly appear informing the user that one of the above requirements is not met.

Finding Work Piece Center



This is a mathematical function which will locate the center between two points. See function section for operation.

+/- Function



Inverts the current position. I.e. multiplies it by -1, so positive position becomes a negative position and vice versa. This function is used to move to a position that is at the same distance on the other side of the zero point. In other words, to machine symmetrical features.

Zero Set



Similar to the zero set function on the main DRO screen but acts upon the selected axis only. Short pressing the button sets incremental origin to zero for the selected axis. Long pressing the button sets the work piece origin to zero for the selected axis.

Audible Alert On/Off



Toggles audible "near zero" alert for the current axis on and off. When selected, the DRO will emit a series of beeps starting at 0.250" (10mm when in metric mode). At 0.100"/5mm, 0.010"/2.5mm and 0.005"/0.1mm the frequency of beeps will increase. When the axis moves to within 0.001"/0.05mm of 0.000, the application will emit one 2-second long beep and stop. The alert is in effect as long as the dialog is open. When the dialog is dismissed, the alert will be turned off.

Settings Menu

Located at the top right of the screen are three vertical dots which, when selected, will give a drop down. Select settings in the drop down to view the settings menu shown below.

Preference Bank

Preference Bank Name

Machine Type

Select this to setup the display for what type of machine the scales are mounted on be it a lathe or mill. This will change the main display is setup. Selecting the type will select it and then automatically close the selection window. Note this manual was written for the mill only.

Readout Display Format

This selection allows for selecting the number of decimal places to be displayed for all axis's. Select the number of digits desired.

Readout Display Font

There are three fonts that may be selected 7 segment, mono and default. Selecting a font only affects axis digits. It is recommended default be used as it gives a smoother easy to read display.

Metric Mode

The setting uses a check box to the right of the menu item. Selecting the check box changes the display from Imperial units to Metric units.

USB Connect

This setting uses a check box to the right of the menu item. If checked, the application will use a USB connection to connect to the scale interface controller over a bluetooth connection.

USB Baud

Sets the transfer rate in BAUD for the USB connection. This setting must match the setting in the scale interface controller or the application might not be able to read the input.

X Axis Label

The default label used to identify the X axis may be changed to a user defined label. This will change the label in the main display and some of the popup dialogs. The value can be set to a non-empty value of any length, but if it's too long some displays might appear broken.

X Axis CPI

Sets the number of counts per inch (CPI) for the X axis. Values for most of the common scales can be found in the X, Y and Z Calibration procedure section, but for better results the scales should be calibrated as described in that section.

X Invert Readout

The axis position uses plus and minus symbols to indicate which direction the axis is traveling. Setting the invert setting will invert or switch the plus and minus symbols. Also note scales can be mounted backwards or upside down. Ensure moving the X axis to the left increments the position display in the positive direction +.001 +.002 +.003 etc for functions to work correctly.

X Digital Filter

If set, the application will average up to 5 readings to reduce the flicker of the last digit when using capacitive scales. Please note, when the filter is enabled the effective refresh rate is five times slower, so there will be significant lag when using slow scales. Excessive flicker may be reduced by replacing the wall power adapter as described in the Install and Connecting the TouchDRO section.

Enable Y Axis

When checked (default), the output from the Y axis will be displayed in the main position screen. This setting has no effect on the function dialogs. I.E. even if the Y axis is disabled, Y dimension input will still appear on some dialogs.

Y Axis Label

The default label used to identify the Y axis may be changed to a user defined label. This will change the label in the main display and some of the popup dialogs. The value can be set to a non-empty value of any length, but if it's too long some displays might appear broken.

Y Axis CPI

Sets the number of counts per inch (CPI) for the Y axis. Values for most of the common scales can be found in the X, Y and Z Calibration procedure section, but for better results the scales should be calibrated as described in that section.

Y Invert Readout

The axis position uses plus and minus symbols to indicate which direction the axis is traveling. Setting the invert setting will invert or switch the plus and minus symbols. Note scales can be mounted backwards or upside down. Ensure moving the Y axis toward you increments the position display in the positive direction +.001 +.002 +.003 etc for functions to work correctly.

Digital Filter

If set, the application will average up to 5 readings to reduce the flicker of the last digit when using capacitive scales. Please note, when the filter is enabled the effective refresh rate is five times slower, so there will be significant lag when using slow scales. Excessive flicker may be reduced by replacing the wall power adapter as described in the Install and Connecting the TouchDRO section.

Enable Z Axis

When checked (default), the output from the Z axis will be displayed in the main position screen. This setting has no effect on the function dialogs. I.E. even if the Z axis is disabled, Y dimension input will still appear on some dialogs.

Z Axis Label

The default label used to identify the Z axis may be changed to a user defined label. This will change the label in the main display and some of the popup dialogs. The value can be set to a non-empty value of any length, but if it's too long some displays might appear broken.

Z Axis CPI

Sets the number of counts per inch (CPI) for the Z axis. Values for most of the common scales can be found in the X, Y and Z Calibration procedure section, but for better results the scales should be calibrated as described in that section.

Z Invert Readout

The axis position uses plus and minus symbols to indicate which direction the axis is traveling. Setting the invert setting will invert or switch the plus and minus symbols. This is used when a scale is mounted backwards.

Z Digital Filter

If set, the application will average up to 5 readings to reduce the flicker of the last digit when using capacitive scales. Please note, when the filter is enabled the effective refresh rate is five times slower, so there will be significant lag when using slow scales. Excessive flicker may be reduced by replacing the wall power adapter as described in the Install and Connecting the TouchDRO section.

Enable W Axis

When checked (default), the output from the W axis will be displayed in the main position screen. This setting has no effect on the function dialogs. I.E. even if the W axis is disabled, Y dimension input will still appear on some dialogs.

W Axis Mode

Provides a way to change the display mode for the W axis. The options are:

- Display (default) - the readout will be shown in the DRO screen just like the other three axis, taking into account the “Enable W Axis” setting.
- Add to X Readout - the readout will be added to the X axis readout.
- Add to Y Readout - the readout will be added to the X axis readout.
- Add to Z Readout - the readout will be added to the X axis readout.

Please note, if one of the latter three options is selected, the application will automatically pre-scale and normalize the readout for both axis. In other words, the CPI and “Invert Readout” settings can be set to different values for the two axis in question.

W Axis Label

The default label used to identify the W axis may be changed to a user defined label. This will change the label in the main display and some of the popup dialogs. The value can be set to a non-empty value of any length, but if it's too long some displays might appear broken.

W Axis CPI

Sets the number of counts per inch (CPI) for the W axis.

W Invert Readout

The axis position uses plus and minus symbols to indicate which direction the axis is traveling. Setting the invert setting will invert or switch the plus and minus symbols. This is used when a scale are mounted backwards.

W Digital Filter

If set, the application will average up to 5 readings to reduce the flicker of the last digit when using capacitive scales. Please note, when the filter is enabled the effective refresh rate is five times slower, so there will be significant lag when using slow scales. Excessive flicker may be reduced by replacing the wall power adapter as described in the Install and Connecting the TouchDRO section.

Enable Tachometer

When checked the output from the tachometer will be shown in the main DRO screen and the chip load output will be enabled (in [Axis Details](#) View).

Tachometer Label

Overrides the default label ("RPM") with a user-set value.

Tachometer PPR

Sets the number of pulses per revolution.

Invert Output

When checked, the output will be inverted. This setting is relevant only when a directional tachometer is used.

X, Y and Z Axis Calibration

By now you should be familiar on how to enter the settings menu and the menu itself. All axis's are calibrated in the same manner but this section will focus on calibrating the X axis. These steps should be repeated the balance of the axis's.

Step 1. Enter the settings menu and enter 30,000 for the X axis CPI.

Step 2. In order to find the correct CPI the X axis must move a known distance accurately at least to .001 or less. For this step a 3" 1-2-3 block is used. Any known item can be used but note the longer the distance traveled the more accurate the CPI reading will be. Securely mount one block squarely to the table. Place the other block next to it and move the table so a test indicator placed against the end of the second block reads zero. Zero the axis readings in the application. Now remove the second block and move the table until the test indicator reads zero when selecting the first block.

Step 3. The number shown on the X axis readout should be now entered into the X axis CPI setting. Verify the readout now reads 3.000" exactly. Calibration is complete.

Some common scale values are listed below.

- iGaging Digimag and AccuRemote – 2560
- Standard (Sylvac) Chinese Scales – 20480
- Harbor Freight Calipers – 2000
- 5 micron Glass/Magnetic Scales – 5080
- 1 micron Glass/Magnetic Scales – 25400

Repeat the above steps for all axis's.

AccuRemote scales use the same electronics as the iGaging DigiMag and appear to be both made by Shahe. The scales are offered in four lengths, but the frame may be made of ground stainless steel or aluminum. For a more in-depth comparison the AccuRemote scales are a bit more repeatable, have smaller run out and will definitely wear much better. The tradeoff is the cost, which is about two times higher for the same lengths.

Resolution .0005"

Accuracy +/-0.002" 0-6", 0.004" 0-12", 0.008" 0-24", 0.013 0-36"

Repeatability .001"

CPI 2560

Refresh Rate up to 50Hz

Default Workspace

In the top right of the main screen you will see “Default Workspace”. A workspace is a way of remembering a set of positions. For example the find center function was used for the X and Y axis so now the display reads zero for both axis's. A new workspace can be created where the X and Y edge of the work piece can be found and zeroed. Switching between the two workspaces the display will show where each axis is with respect to either the center or edge of the work piece. Select Default Workspace to create a new workspace. Once created select it again either workspace can be selected to switch between. The use of the capability will become more clear when using the Hole Circle function. The workspace command menu can be displayed by selecting the three vertical dots located to the right of the workspace icon.

Setting An Absolute Dimension

Absolute positioning or dimensions are used to set or remember a specific spot or location on the work surface. Any axis can be manually set to a dimension or specific value. For example to remember the center of a hole circle move the X and Y axis to the center of the circle. Pressing Set Zero will set all axis to zero in the incremental display but leave the absolute position untouched. Select the position digits for an axis then select the digits in the pop up. Check the box for setting absolute position and enter zero. Select any axis position digits to open the Axis Details menu for that axis. In the display select the Position to open the set position menu. Using the keyboard enter the vale desired and check the box for Set Absolute Dimension and select Set Dimension.

NOTE: Some of the tasks in the following sections use pop up menus. Be aware there are small icons below these menus which allow moving to the next item, lowering the menu and so on. In addition any function which allows a preview of the work can be zoomed in using the standard two finger spreading motion.

Finding Work Center Function

Note this function can be seen on YouTube on the TouchDRO channel. Using an edge finder locate one edge of the part. Select the axis position digits for the Axis Details menu. Select the Zero Set for the axis. Locate the other edge of the part. Select the axis position digits for the Axis Details menu again. Select the $\frac{1}{2}$ button. The display now reads the center point. Move the axis until the display reads zero. Long pressing the Zero Set button in the main menu will set the workspace origin to the current position.

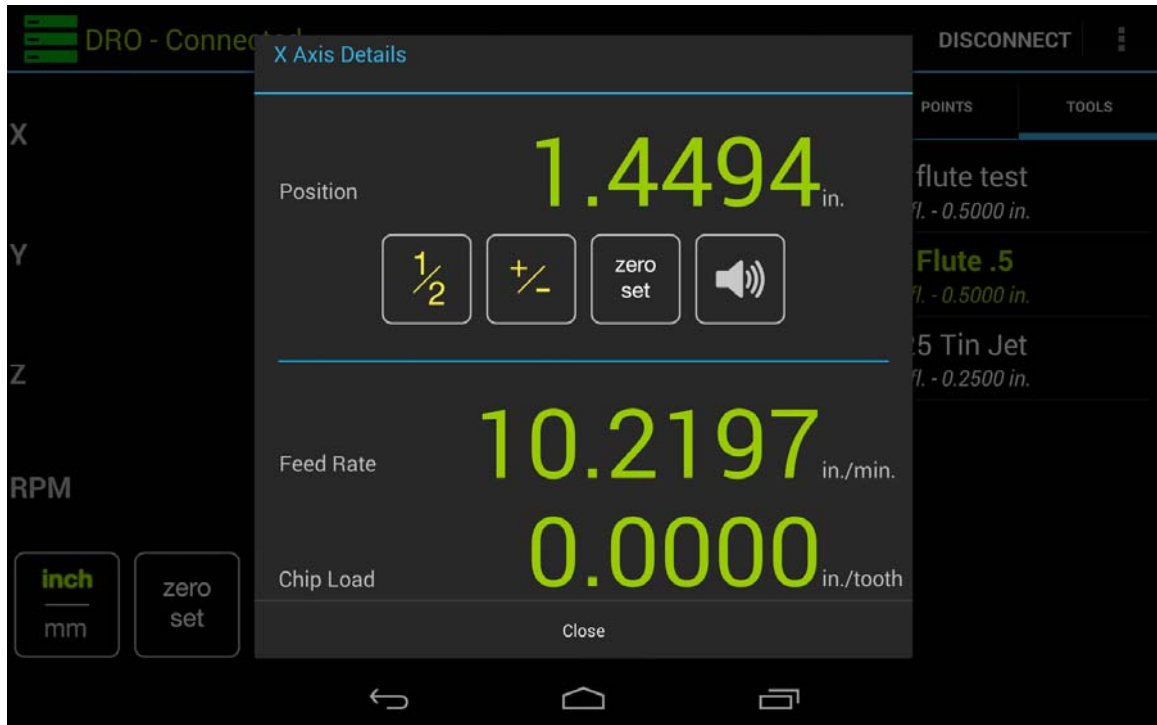

Locating the Work and Setting the Origin

Note this function can be seen on YouTube on the TouchDRO channel

Hole Circle Function

Note this function can be seen on YouTube on the TouchDRO channel. First select the hole circle icon from the main screen to bring up the hole circle menu. Next enter the radius of the circle desired. This will be a circle centered on the current spindle location. Next enter the number of holes desired in the circle. Note the maximum number of holes cannot exceed 100. While the keyboard is on screen you can scroll item vertically for the next entries. The angle entries can be left at zero for a full circle. Angle a is the angle degrees of where the first hole is located. Example entering 45 will cause the first hole to be located 45 degrees clockwise from the top.. Angle theta is how many degrees the holes are to be placed in. For example for a half circle enter 180. By selecting the three vertical dots to the right of the text

Workspace a preview of the hole circle can be seen. In the preview window select center on screen and auto-select nearest point. It is important to check the auto-select box for easier operation. Now move the X and Y axis to the first hole until the X and Y readout in the window reads zero. The spindle is now located to drill the first hole. After drilling the first hole move X and Y to the next hole. The readout will automatically switch to hole two for positioning. Repeat until all holes are drilled. NOTE: If, in the preview screen, an axis appears to be moving in the opposite direction then the scale has been mounted upside down. To correct this check the axis invert in the settings menus.

The Tool Library

The tool library is used by the application to calculate a tool offset with respect to the work piece. The distance the end mill must be moved so it just touches the work piece when the spindle center is located at the work piece edge. The application also uses tool information to calculate chip load data. Finding the offset is especially useful when an offset calculation requires a calculator over simple mental division. Example $\frac{1}{2}'' = .250''$ but $\frac{5}{8}'' = ?$. To add a tool select the three vertical dots top right and select Add Tool. Enter a tool name then optionally enter a description. Enter the tool diameter then the number of flutes. Last enter zero for the Z offset and select save. The tool can now be seen in the library. To edit a tool long select it from the tool library then select edit tool.

Setting a Tool Offset

To run an offset select the tool from the library. In the pop up menu, select where the spindle center is currently located by selecting Tool Position. Note the location menu can be scrolled. Optionally a Z Offset can be entered which is the current position the tool is from the work piece. Once done select set tool offset. Now the axis read out will have red digits indicating half the diameter of the tool from its current position. Move the axis until all axes read zero then deselect the tool. The tool is now located at the edge of the work piece.

Adding a Custom Point

This function is useful for remembering and locating a specific work piece point for future use. To add a point, select "add point" from the main screen. Next long select the point that was added to the workspace and select edit point. Enter the point name and custom axis locations to be remembered and select save point. To move to the saved point select it from the workspace then select absolute positioning for each axis involved. Move each axis until the read out shows zero. Deselect the point. The spindle center is now located at the point stored.

Arbitrary Hole Circle

This function is useful for defining a hole pattern needed for items such as connectors, cosmetic holes or anything requiring an odd hole pattern. Select the arbitrary hole icon from the main menu to bring up the function. Enter the circle radius desired. Enter the location of the hole as an angle. For example entering zero will place a hole straight back on the work piece and 90 will place it to the right of the

mill. As many holes can be entered by typing in the angle then select the plus icon. To view all the entries select the left arrow at the bottom of the screen. All entries can be scrolled thru and deleted if necessary. Select "Create Circle" when done. Next select the three vertical dots next to "Workspace" the select preview workspace. The view shows the hole locations for drilling. Make sure auto-select nearest point is checked before proceeding. Note with some experimentation this function can be used to mill an outside arch or radius on a work piece. The smaller the degree steps will create a much smoother radius result. When experimenting always move the axis which will not cut first then move the cutting axis. Typically 30 points for a 1" radius will yield good results.

Step and Repeat Function

Note this function can be seen on YouTube on the TouchDRO channel. Select the Hole Pattern icon. Enter How many times the pattern is to be repeated in the X axis. Enter in how many inches the next hole is to be located in the X axis from the current spindle position. Repeat this for the Y axis. Typically the Y repeat should match the X repeat. Enter the angle of the pattern. Leaving this empty will result in a no angle entry. selecting the three vertical dots to the right of the text Workspace a preview of the hole circle can be seen. In the preview window select center on screen and auto-select nearest point. It is important to check the auto-select box for correct operation. Now move the X and Y axis to the first hole until the X and Y readout in the window reads zero. The spindle is now located to drill the first hole. After drilling the first hole move X and Y to the next hole. The readout will automatically switch to hole two for positioning. Repeat until all holes are drilled.

Adding A Tachometer

The TouchDRO supports the addition of an external tachometer when this option is enabled. See the settings menu for details. The connector for the tachometer is located inside the TouchDRO's enclosure and is labeled "Tach" on the PCB. The pins are as follows: 1- +3.3VDC, 2 – Tach A input signal, 3 – Tach B input leave open, 4 – Ground. It is easiest and suggested to use a hall effect sensor with magnets mounted on a rotating item. This type of sensor can be found on Amazon search for "hall sensor module for arduino" and can be easily connected to the TouchDRO PCB. The Tach A input is the primary signal and Tach B is suspected to increment the count when low and decrement the count when high. NOTE: Any power line noise will effect RPM readings.

Presetting A Dimension

An axis position readout can be manually entered for any axis. In the main screen touch the axis position digits for the axis to be set. In the pop up window touch the axis position digits again. A pop up keyboard will allow entering a new position.

Appendix



Micro-USB pinout		Pin	Name	Color	Description
<p>www.Electronicslovers.com</p> <p>Micro-USB is a standard USB connector for a wide range of portable devices, including cell phones and smartphones pinoutsguide.com/PortableDevices/micro_usb_pinout.shtml</p>	1	VCC	Red	+5 V	
	2	D-	White	Data -	
	3	D+	Green	Data +	
	4	ID	none	permits distinction of Micro-A- and Micro-B-Plug Type A: connected to Ground Type B: not connected	
	5	GND	Black	Signal Ground	

NOTE: TouchDRO does not support the probe input signal as of this publication

TouchDRO Revision 2.1 PCB

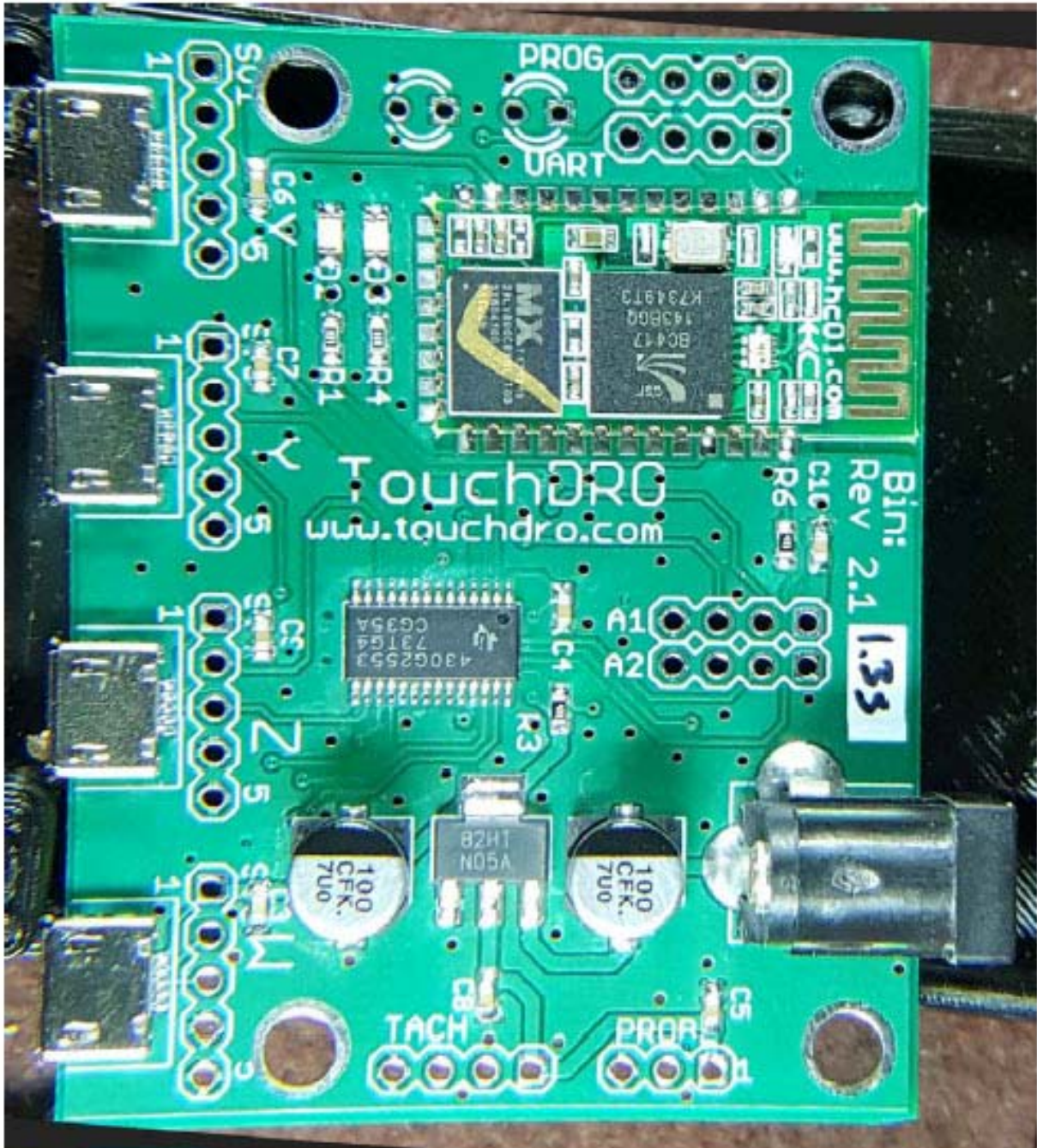

Suggested Transformer Power Source



Use a 6 or 12 volt class 2 transformer type AC adapter.

Note: The maximum input voltage is 20VDC

The TouchDRO board uses a common 2.1mm x 5mm center-positive DC power jack, similar to the one used by the Arduino boards, therefore any power adapter that provides 5-9V and at least 200 mA will work. If possible, it is recommend using an old-style linear "wall wart" adapter with a transformer, as opposed to the newer switching ones. Capacitive scale have their frames connected to the ground, which creates a large ground loop between the machine and the TouchDRO board, which can cause problems under some circumstances. An old style transformer power supply provides a way to cut this loop.

Capacitive scales by their nature are more susceptible to noise and interference than glass or magnetic DRO scales. It is, therefore, extremely important to properly ground your DRO setup to avoid random scale resets or position jumps. Ideally there should be no loops in the ground connection, but since all of scales supported by this controller have their frames grounded, the only practical way to eliminate the loops between sales and the board is to use non-conductive mounting hardware or omit the ground connections to the scales and ground the board to the machine frame. In practice this might not be needed unless you have noise equipment or a powerful motor that creates a lot of noise in the AC lines. More critical is the loop between the machine frame and the scale's power supply. That loop should either be eliminated using a mains-isolating power supply (i.e. an old-style heavy wall wart), or if that is not possible, kept as short as possible.

Note: The TouchDRO with 3 scales attached draws 55ma thus a 9V battery may be used and will last about 6 hours or a 6V lantern battery will last about 36 hours.

Status LEDs

The board has two status LED's green and blue.

Green LED

The green LED is used by the processor to display the adapter data acquisition status. It can be in two states:

- Board is in protocol detection mode - fast blinking
- Board is ready to receive position - once per second blinking

Blue LED

- Board not paired - two pulses per second
- Board paired but disconnected - short pulse every 2 seconds
- Board connected - two short pulses every 2 seconds

The blue LED is connected directly to the Bluetooth transceiver and indicates the Bluetooth connection status.

TouchDRO Revision 2.1 Schematic

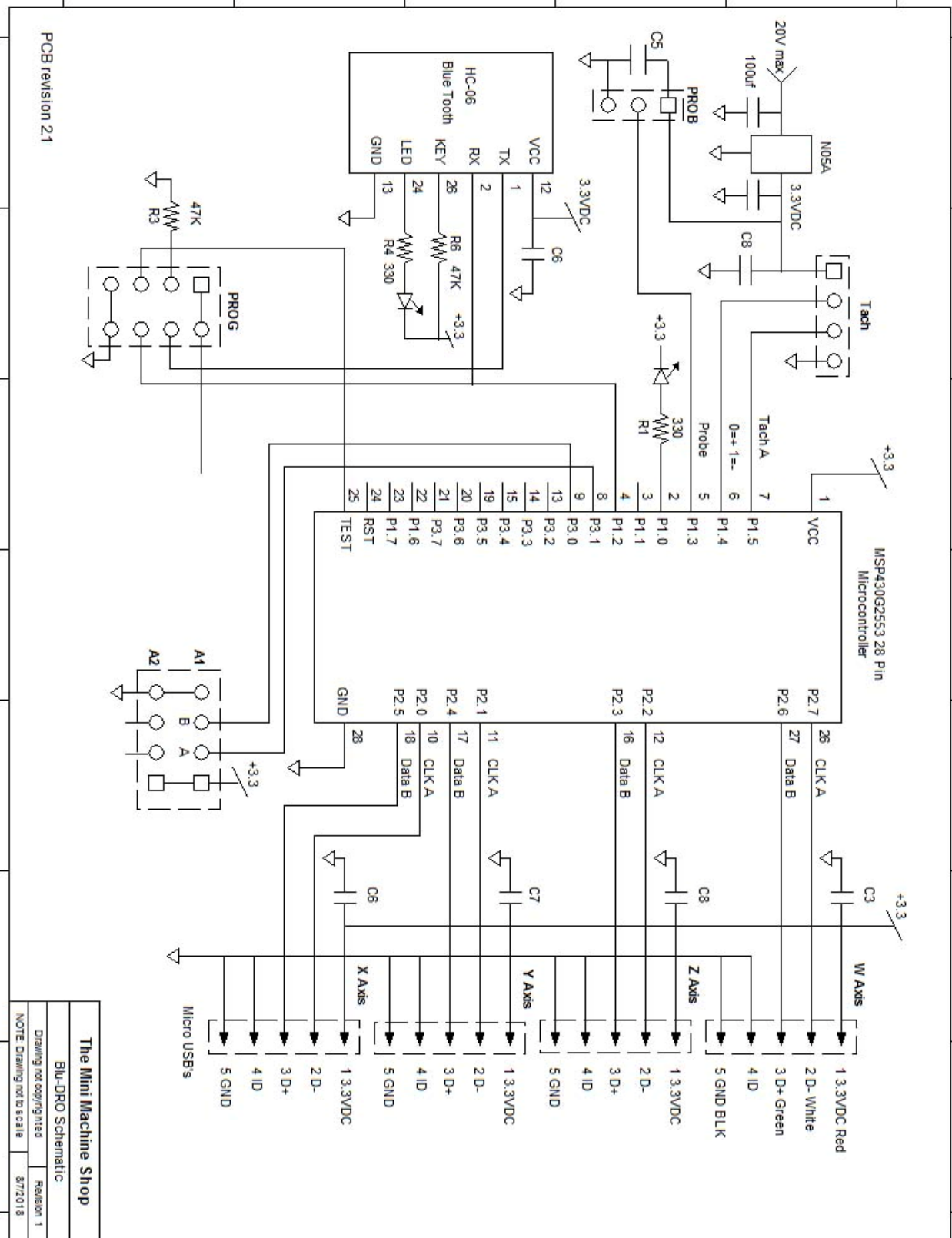

The Mini Machine Shop	
Blu-DRO Schematic	
Drawing not copyright	Revision 1
NOTE: Drawing not to scale	
8/7/2018	

Sainsmart Hall Effect Schematic

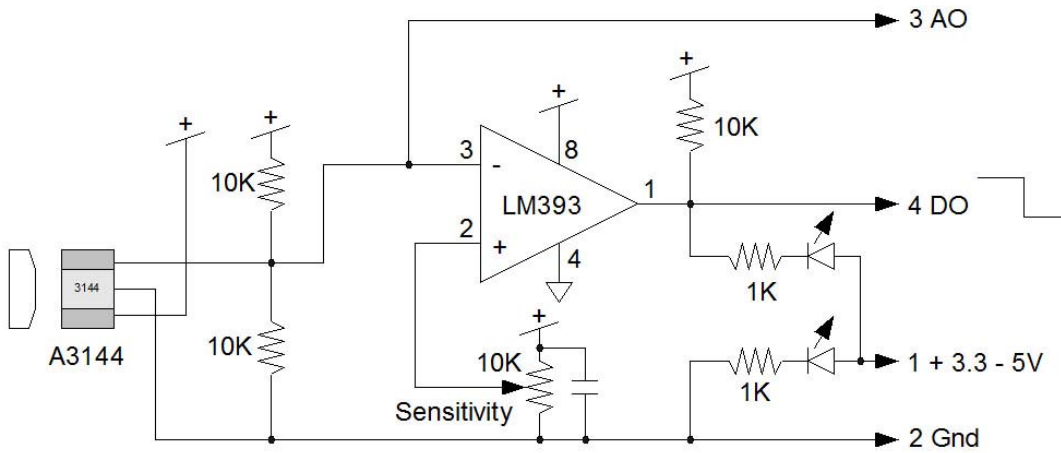

Sainsmart To TouchDRO

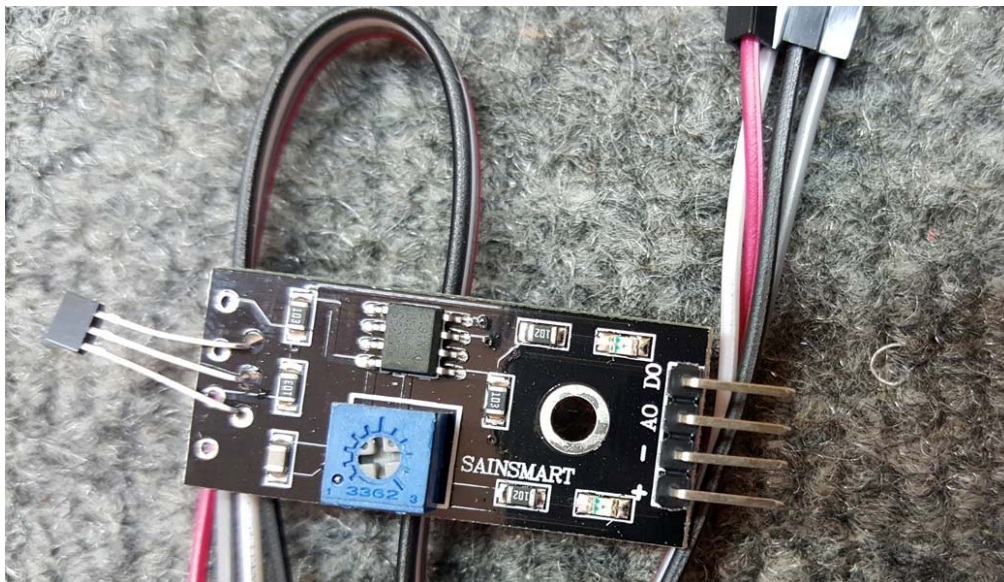
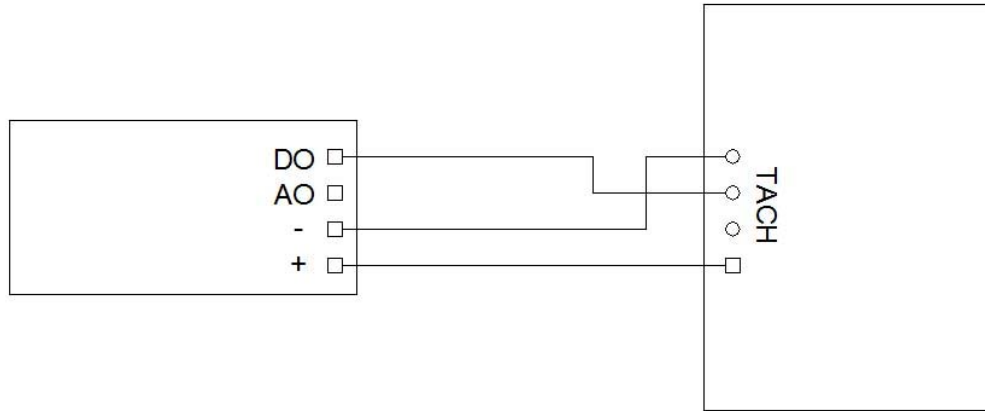

Trouble Shooting Guide

An axis position occasionally displays a random location then returns to the correct location.

The position of an axis or its location is stored in the scale pickup. Some older scales manufactured before 2015 occasionally transmit incorrect position information by dropping location bits when updating the axis position. The solution is to either ignore the random jump or replace the scales with newer ones.

The axis 1/10 or .0001 digit is randomly changing or jumping.

See the appendix for using a transformer type wall power supply or consider using a battery for power.

Unable to pair with the TouchDRO.

Check the appendix section on status LEDs. Ensure they are in the correct state. Ensure your device has Bluetooth turned on and refresh the scan for devices.