

***ADVANCED ELECTRIC GENERATOR & CONTROL
FOR
HIGH SPEED MICRO/MINI TURBINE BASED POWER SYSTEMS**

Jay Vaidya, President Electrodynamics Associates, Inc.
409 Eastbridge Drive, Oviedo, FL 32765
and
Earl Gregory, Power Generation, Propulsion Directorate
AFRL/PRPG, Wright-Patterson AFB, OH 45433

**Patent Pending*

INTRODUCTION

High-speed micro-turbines and mini-turbines play a significant role in the Distributed Power Systems that provide dependable electric power close to the user. Several high-speed turbo-generators manufactured by various corporations are now available in the 30 kW to 90 kW range. These systems operate at speeds from 50000 RPM to 120000 RPM. The generator is directly coupled to the turbine shaft. This obviates the need for a gearbox, helps reduce the size of the generator, and lowers the cost of the overall system. The output power is electronically processed and conditioned to provide constant voltage dc or multi-phase ac power at constant frequency.

Technology of micro-turbines is moving forward to address ratings above 100 kW due to the growing demand for larger units. There is a tendency to use multiple units of the existing 30 to 90 kW packages to satisfy this demand for higher power capacity. However, use of turbo-generators of higher ratings is likely to be beneficial to the user for the following reasons:

- a) lower cost of investment per kW for purchase and installation
- b) lower cost of maintenance because of reduced parts count
- c) higher efficiency
- d) safer operation.

At the present time most generators used with micro-turbines are based on permanent magnet technology. It is the objective of this paper to compare alternatives to the PM generator technology, and introduce induction generator technology as a more viable alternative in the power range exceeding 100 kW. The approach in this paper is to present the concept in all its dimensions including the issues of generator and controller design. The authors are currently engaged in the development of the high-speed induction generator systems. Their experience in the field of the technology forms the basis supporting the discussions in this paper.

SYSTEM DEFINITION AND CONSTRAINTS

It is realized that one specific technology does not necessarily provide the best answer under all situations. We must therefore limit our discussions to applications within certain constraints. At this time the following broad limits are applicable for the technology under consideration:

- i) The micro or mini turbine systems considered here are in the 100 kW to 500 kW power range. The system comprises mainly of high-speed turbine, generator, controller, protection, and instrumentation.

The generator and the turbine are directly coupled. Figure 1 shows the components in a block diagram.

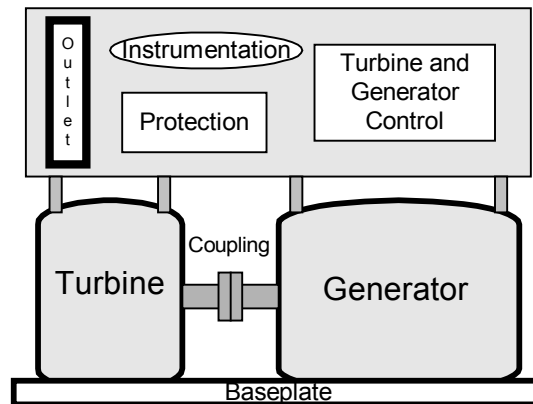

Figure 1: Micro- or Mini- Power Principal Components

- ii) The prime mover operates at speeds between 30000 to 80000 RPM depending upon the rated output. Typically, the operating speed of the prime mover varies inversely with the rated output.
- iii) Constant speed of operation is considered. However, certain narrowly defined operating speed range may be required in specific applications.
- iv) The generator must be designed for a cooling system that is compatible with the system requirements. Typically either air, or lubricant oil, or water glycol mixture is used.
- v) The integrated power system is located close to the user such as in a factory building, hospital, department store, and office complex. Alternatively, vehicle mounted applications in airborne, land based or marine situations are also considered. These mobile applications are valuable particularly for military requirements.
- vi) The electrical power output is typically 3-phase ac with single or multiple voltages. Alternatively, DC output may be required. In case of AC power systems, 50/60 Hz.

frequency is common for commercial applications, and 400 Hz. frequency is used in military / aerospace applications.

- vii) Compatibility with utility power systems may or may not be required. In most situations stand-alone capability in isolation from a utility system is required. In some other situations, power transfer from utility to the turbo-generator and vice versa may be necessary.
- viii) The generator must also provide electric start capability during the initial start up of the turbine.
- ix) The system must provide protection against hazards. Safety of operation is an important consideration.

In approaching various issues, we have considered the following issues to define relative merits:

- i) Cost: Investment and Operational
- ii) Reliability and safety
- iii) Size, Power Density.

The issues listed above are not necessarily listed in the order of their importance.

GENERATOR TECHNOLOGIES

We plan to review three different generator technologies for comparison: permanent magnet (PM), induction, and switched reluctance (SR). All these three are suitable for high-speed operation in the speed range considered here. There are other technologies such as synchronous reluctance and homopolar that are suitable for high-speed operation but are not considered in this paper. We also limit our discussion to radial geometric configurations for the three technologies. Axial gap geometric configurations are not considered.

Permanent Magnet (PM)

Micropower systems currently in the market use the generator designs based on the PM technology. The generator itself has two electromagnetic components: the rotating magnetic field constructed using permanent magnets; and the stationary armature constructed using electrical windings located in a slotted iron core. Figure 2 shows the construction of a typical PM generator in a cross sectional view.

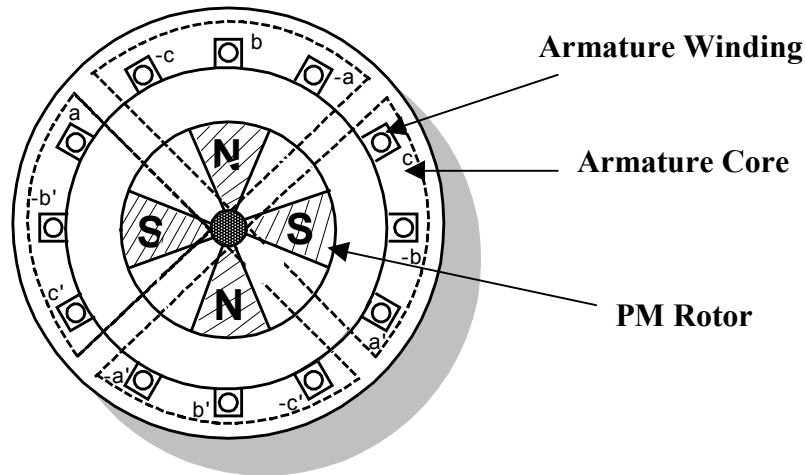

Figure 2: Permanent Magnet Generator Cross-sectional view

The PM's are made using high-energy rare earth materials such as Neodymium Iron Boron or Samarium Cobalt. Retention of the PM's on the shaft is provided by high strength metallic or composite containment ring. The stationary iron core is made of laminated electrical grade steel. Electrical windings are made from high purity copper conductors insulated from one another and from the iron core. The entire armature assembly is impregnated using high temperature resin or epoxy.

The voltage output from the generator is unregulated, multiple phase ac. This voltage varies as a function of the speed and load. This voltage output is connected to a solid state power conditioning system. Typically, the solid state power conditioning system uses buck/boost techniques and regulates the entire power output.

Induction

The technology of induction generator is based on the relatively mature electric motor technology. Induction motors are perhaps the most common types of electric motors used throughout the industry. Early developments in induction generators were made using fixed capacitors for excitation, since suitable active power devices were not available. This resulted in unstable power output since the excitation could not be adjusted as the load or speed deviated from the nominal values. This approach became possible only where a large power system with infinite bus was available, such as in a utility power system. In this case the excitation was provided from the infinite bus. With the availability of high power switching devices, induction generator can be provided with adjustable excitation and operate in isolation in a stable manner with appropriate controls.

Induction generator also has two electromagnetic components: the rotating magnetic field constructed using high conductivity, high strength bars located in a slotted iron core to form a squirrel cage; and the stationary armature similar to the one described in the previous paragraph for PM technology. Figure 3 shows the construction of a typical induction generator in a cross sectional view.

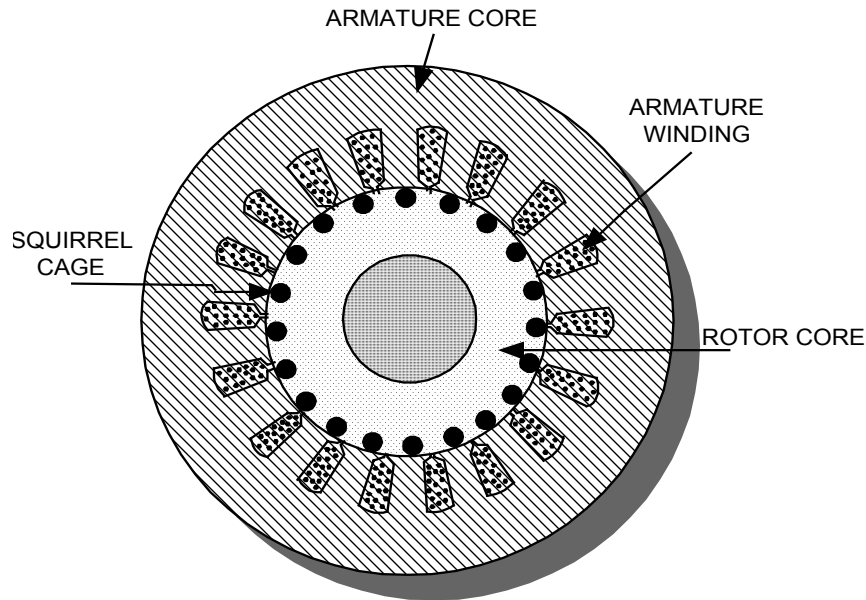
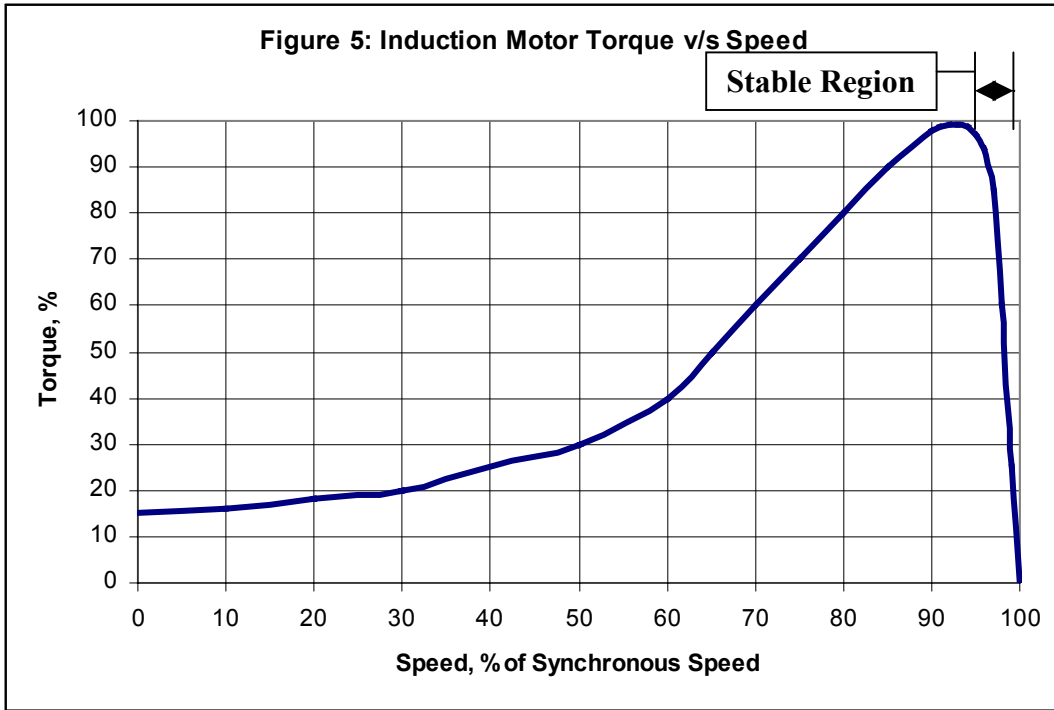

Figure 3: Induction Generator Cross-sectional view

The voltage output from the generator is regulated, multiple phase ac. The control of the voltage is accomplished in a closed loop operation where the excitation current is adjusted to generate constant output voltage regardless of the variations of speed and load current. The excitation current, its magnitude and frequency is determined by the control system. The excitation current is supplied to the stationary armature winding from which it is induced into the short circuited squirrel cage secondary winding in the rotor.

Switched Reluctance (SR)

The technology of SR generator is based on the concepts that magnetically charged opposite poles attracts. Typically, there are unequal number of salient poles on the stator and rotor. Both are constructed of laminated electrical grade steel. Figure 4 shows a cross sectional view of the construction of the SR generator. The number of poles shown on the stator is 6. The number of poles shown the rotor is 4. Other pole combinations such as 8/6, 10/8 are possible. There is no winding on the rotor. Armature coils located on stator poles are concentric and are isolated from one another. When the coils on opposite poles such as 1 and 1 shown in Figure 4, are excited the corresponding stator poles are magnetized. The rotor poles A-A are closest to the stator poles 1 and 1. These are magnetized to opposite polarity by induction and are attracted to



If the induction motor is driven to a speed higher than the synchronous speed, the speed torque curve reverses as shown in Figure 6. In the stable region of this curve, electric power is generated utilizing the mechanical input power from the prime mover. Once again the generated power is a function of the slip, and varies with the slip itself.

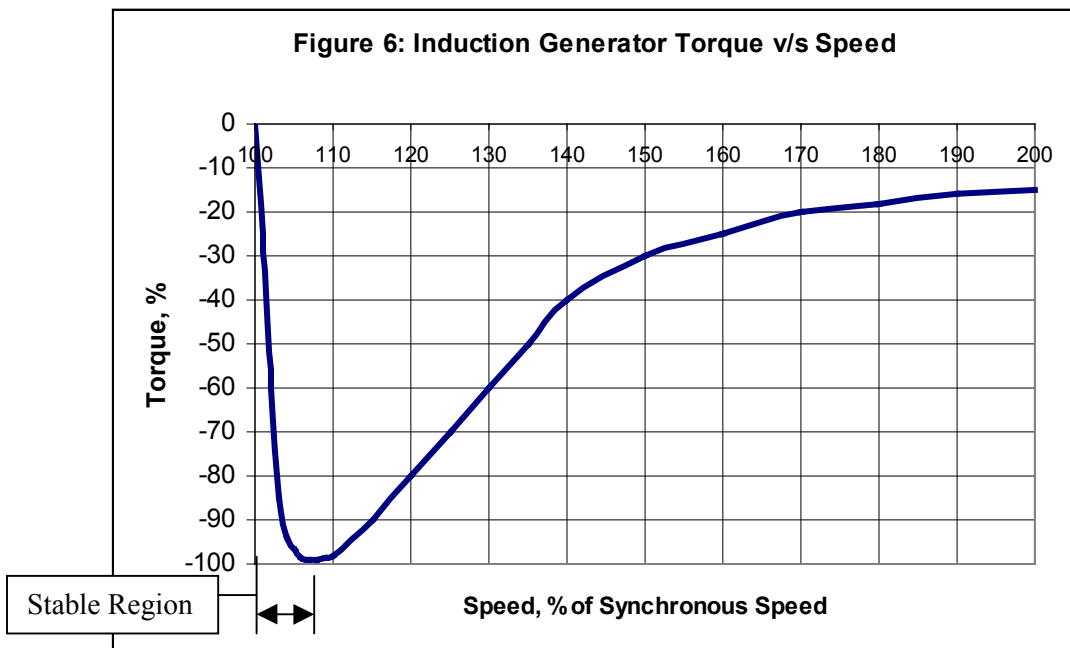

In the generator mode, if the slip is controlled in accordance with the load requirements, the induction generator will deliver the necessary power. It must be remembered that the synchronous speed is a function of the electrical frequency applied to the generator terminals. On the other hand, the operating shaft speed is determined by the prime mover. Therefore to generate power, the electrical frequency must be adjusted as the changes in the load and the prime mover speed occur.

In addition to the requirement stated above, the excitation current must be provided to the generator stator windings for induction into the rotor. The magnitude of the excitation current will determine the voltage at the bus. Thus the excitation current must be regulated at specific levels to obtain a constant bus voltage. The controller for the induction generator has the dual function as follows:

- i) Adjust the electrical frequency to produce the slip corresponding to the load requirement.
- ii) Adjust the magnitude of the excitation current to provide the desirable bus voltage.

Figure 7 depicts the region of generator mode operation for a typical induction generator. A number of torque speed characteristic curves in the stable region of operation are shown to explain the operation. As an example, consider the situation when the prime mover is at the nominal or 100% speed. The electrical frequency must be adjusted to cater for load changes from 0 to 100% of the load. If a vertical line is drawn along the speed of 100%, it can be observed that the electrical frequency must be changed from 100% at no load to about 95% at full load if the prime mover speed is held at 100%.

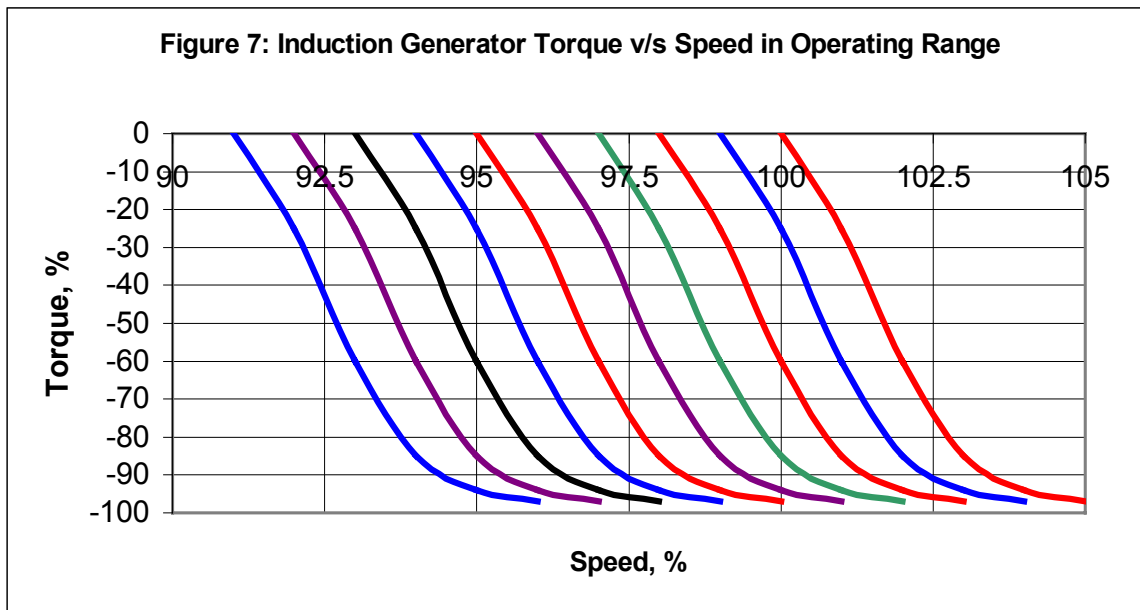

BENEFITS OF INDUCTION GENERATOR TECHNOLOGY

Induction generator has several benefits to offer for the micro, mini power systems under consideration. These benefits relate to the generator design as follows:

- i) **Cost of Materials:** Use of electromagnets rather than permanent magnets means lower cost of materials for the induction generator. Rare earth permanent magnets are substantially more expensive than the electrical steel used in electromagnets. They also must be contained using additional supporting rings.
- ii) **Cost of Labor:** PM's require special machining operations and must be retained on the rotor structure by installation of the containment structure. Handling of permanent magnets that are pre-charged is generally difficult in production shops. These requirements increase the cost of labor for the PM generator.
- iii) **Generator Power Quality:** The PM generator produces raw ac power with unregulated voltage. Depending upon the changes in load and speed, the voltage variation can be wide. This is all the more true for generators exceeding about 75 kW power rating. On the other hand with SR generator, the output waveforms are non-sinusoidal and peaky as shown in Figure 8. These waveforms must be filtered in order to get reasonably constant voltage output.

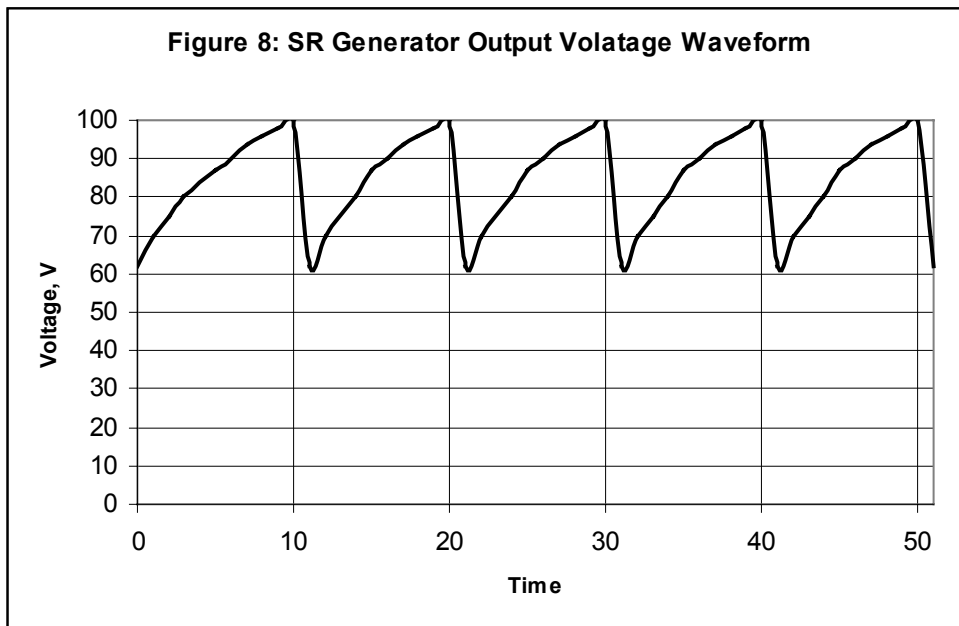

The induction generator produces ac voltage that is reasonably sinusoidal as shown in the example from an actual test in Figure 9. This voltage can be rectified easily to

produce a constant dc voltage. Additionally, the ac voltage can be stepped up or down using a transformer to provide multiple levels of voltages if required.



Figure 9: Induction Generator AC Output Voltage Waveform

- iv) **Fault Conditions:** When an internal failure occurs in a PM generator, the failed winding will continue to draw energy until the generator is stopped. For high-speed generators, this may mean a long enough duration during which further damage to electrical and mechanical components would occur. It could also mean a safety hazard for the individuals working in the vicinity. The induction generator on the other hand is safely shut down by de-excitation within a few milliseconds, preventing the hazardous situations.

INDUCTION GENERATOR CONTROLLER TECHNOLOGY

The controller may be broadly divided into three sections, namely, the power section, sensing circuits, and the control section. Power transistors using IGBT's or MOSFET's are used in the power section of the generator controller in a conventional multi-phase configuration, the number of phases being the same as the number of phases in the generator winding. Anti-parallel diodes are connected across each of the transistor. The DC rail is connected to a power capacitor. An additional power inverter is used when an AC output at a constant frequency such as 60 or 50 Hz. is required. Sensing of currents and voltages is provided at the load as well as in the power section of the controller. In addition, the speed of the shaft is measured. All the parameters sensed by the sensing circuits are conditioned by filtering and digitizing as required. The control section receives the information provided by the sensors. The parametric model of the generator is incorporated in the control section. In conjunction with a PID control algorithm, appropriate switching commands for the power transistors are generated in the control section. This creates the necessary frequency and amplitude of the excitation currents that flow in the induction generator windings and are induced into the squirrel cage rotor. The control section also includes protective functions such as over-current, over-voltage, and over-temperature protection circuitry. Figure 10 shows the controller in a block diagram.

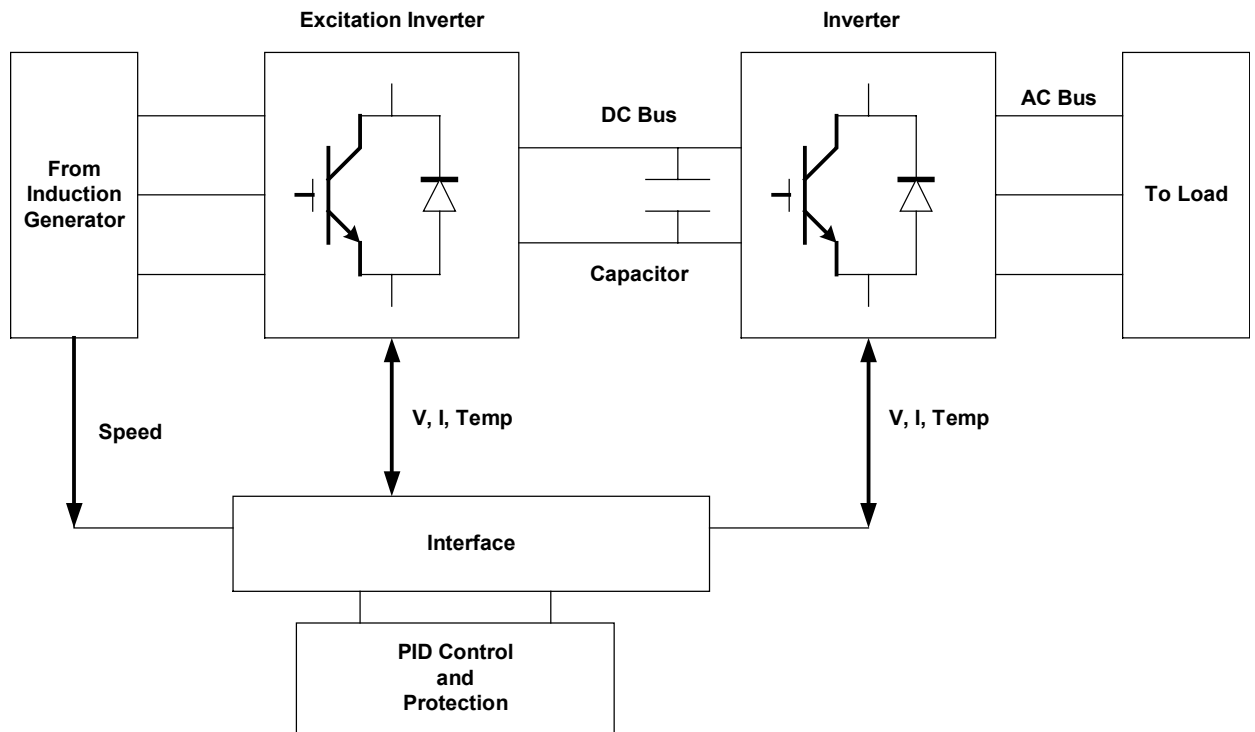

Figure 10: Controller Block Diagram

INDUCTION GENERATOR CONTROLLER BENEFITS

When compared to PM and SR generator controllers, induction generator controller offers the following benefits:

- i) **Sensing:** The control of induction generator slip requires precise measurement of speed. On the other hand, the control of SR generator requires precise measurement of the rotor position. This is a much more difficult task to accomplish than the measurement of speed.
- ii) **Switching and control speed:** For the SR generator, the operating frequency is extremely high, in the range of 6 kHz. at 60000 RPM. This requires high speed switching of power transistors. The switching commands also must be provided at a high rate. For the induction generator, the operating frequency is in the 1 kHz. to 2 kHz. range at 60000 RPM depending upon whether 2 pole or 4 pole generator design is selected. The switching rate for the power transistors can be lowered in a reasonable range.

- iii) **Power Section Sizing:** In the case of PM generators, due to the wide variation in the voltage output, complexities are introduced in the controller requiring voltage boost mechanisms. The power electronic components must function at high stress levels. In the SR generator controller, high rates of change of currents and voltages result in high stress levels for the power electronic devices. The induction generator has a well-regulated sinusoidal output that can be conditioned without using highly stressed electronic components.

Overall it is believed that the controller for the induction generator is more robust, smaller in size, and cost less than the controller for PM or SR generators in the power range under consideration.

STATUS OF CURRENT TECHNOLOGY

Electrodynamics Associates, Inc. is currently developing a 125-200 kW induction generator to operate at 62000 RPM on an SBIR Phase II contract from AFRL/WPAFB, Dayton, OH. The generator is an air-cooled design. An identical machine has built to operate as a motor. The generator and the motor are mounted on a base plate and coupled together. An optical speed counter is attached at one shaft extension. Figure 11 shows the photograph of this assembly.

Figure 11: Induction Generator and Motor Coupled Set

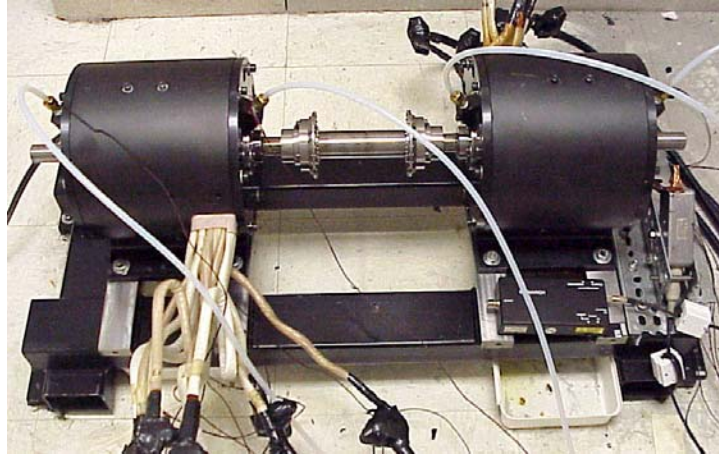

Controllers for both the generator and the motor have been developed for the test purposes. The control functions are embedded in a software model and the PC in the loop system using MathWorks™ software packages is used. The controller set up is shown in Figure 12.

Figure 12: Controller Setup for Induction Generator and Motor



At the time of writing this paper, the motor generator test set up is operational and tests have been completed to 67 kW power output from the generator at 24000 RPM. The generated power on the dc bus is fed back into the motor, so that only the losses in the motor generator set are provided from the utility bus. Tests are continuing at higher speeds to demonstrate the rated power by the end of the current calendar year. During the next phase of this project, improvements in the controller are planned. Use will be made of current technology DSP'S or ASIC'S along with more compact power electronic components to reduce the controller size.