

Series 06 Cartridge Cavities

Saturday, August 11, 2007

12:02 AM

TECHNICAL REFERENCE

Series 06 Cartridge Cavities

VC06-1

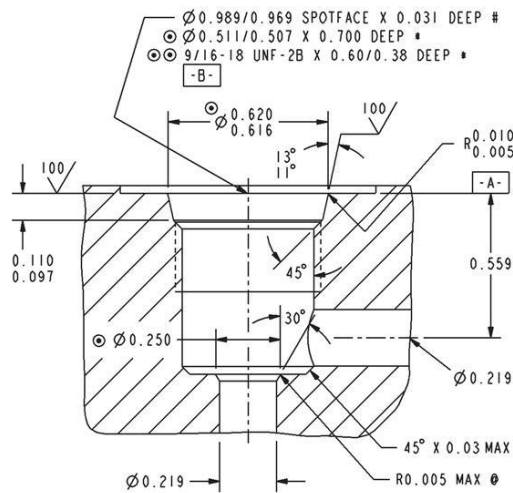

VC06-1
NOTES:

- | | | | |
|-------|---|--------|-------------|
| | | | |
| 0.001 | A | 0.001 | A |
| 0.002 | B | 0.0009 | (PITCH DIA) |
- * - DEPTHS ARE FROM DATUM -A- .
- # - UNLESS OTHERWISE SPECIFIED ON MACHINING DRAWING.
- UNSPECIFIED TOLERANCES ARE ± 0.005 .
- UNSPECIFIED ANGULAR DIMENSIONS $\pm 3^\circ$.
- θ - THIS SURFACE IS A VALVE SEAT. IT MUST BE FREE OF NICKS AND TOOL MARKS.

VC06-2

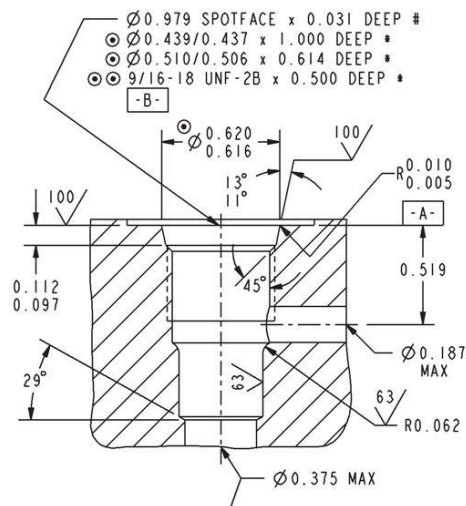

VC06-2
NOTES:

- FEATURES (EXCEPT FOR PILOT DRILL AND CROSS DRILLS) CAN BE MACHINED SIMULTANEOUSLY USING HYDRAFORCE FORM TOOLS. CONSULT FACTORY.
- | | | | |
|-------|---|--------|-------------|
| | | | |
| 0.001 | A | 0.001 | A |
| 0.002 | B | 0.0009 | (PITCH DIA) |
- * - DEPTHS ARE FROM DATUM -A- .
- # - UNLESS OTHERWISE SPECIFIED ON MACHINING DRAWING.
- UNSPECIFIED TOLERANCES ARE ± 0.005 .
- UNSPECIFIED ANGULAR DIMENSIONS $\pm 3^\circ$.
- ** - FEATURES OF VARIATION 'A' ARE ONLY REQUIRED IF NOTED ON A SPECIFIC PRODUCT CATALOG PAGE.

NOTE: CAVITY VARIATION 'A' **
MINIMUM PILOT DRILL $\varnothing 0.375$ TO
MINIMUM DEPTH OF 1.10 FROM DATUM -A-